

DIAPHRAGM DOSING SYSTEM FEM 1.03 / 1.08

DATA SHEET E 755



FEM 1.03 KPRC



FEM 1.08 KPRC



Concept

FEM 1.03 / 1.08 – The alternative solution to syringe, piston, gear and peristaltic pumps for dosing and transfer applications.

The FEM diaphragm dosing pump has been specially developed in order to accurately dose small quantities of liquid over a long period of time whereby two of its most distinctive features are its compact size and robustness (pump and electronics). The FEM pump and electronics makes a complete dosing system which is suitable for both simple as well as complex applications. With the functions „quasi continuous flow“ and „batch dispensing“ the FEM diaphragm pump differentiates itself from pumps based on alternative technologies eg. piston, gear, syringe and peristaltic pumps. Other interesting features are its high reliability, a favourable purchasing price and low maintenance costs.

KNF has developed a specially programmed electronic control module so that the integrated solenoid valve and the movements of the diaphragm are exactly synchronised. This results in an exact dosing which is gentle and low in pulsation. In addition to these unique pump characteristics the control module also allows a wide range of control possibilities to be used eg. serial interfaces.

The dosing pump is self priming, maintenance free and can be run dry.

Advantages

- Dosing a continuous flow (RUN mode)
- Dosing a definite volume, batches (DISPENSE mode)
- Maintenance free (>10,000 h >10⁸ cycles)
- Good price/performance ratio

Features

- Excellent repeatability
- Constant results over a long period of time
- Large dosing range 1:1,000
- Low pulsation
- High chemical resistance
- Self priming
- Run dry safe
- Long life
- Various control possibilities

Areas of use

- Medical diagnostics
- Industrial dosing systems
- Precision cleaning
- Fuel cells
- Semi conductor industry
- Water analysis
- Others

Performance Data

Type	Flow rate (ml/min)	Suction head (mWg)	Pressure head (mWg)
FEM 1.03	0.03 - 30	4	60
FEM 1.08	0.08 - 80	3	40

The KNF Modular Concept of Selection



General note

This data sheet includes information about the technical characteristics of the FEM 1.03 / 1.08 pump types. More detailed information and explanations can be found in the operating instructions (available on request).

Flow curves

The flow curves show how the performance of the pumps changes relative to different suction heights and pressures. In the case of a combination of both pressure and suction height then we would very happy to advise what the expected flow rate would be.

The values given in the curves are dependant upon the liquid, choice of head materials and the type of hosing being used therefore a certain deviation is to be expected.

The flow rate is measured with water at 20°C.

Functions

PRIME mode

Max. pump speed used for filling the system, removing air bubbles or rinsing.

RUN mode

Dosing a continuous flow rate.

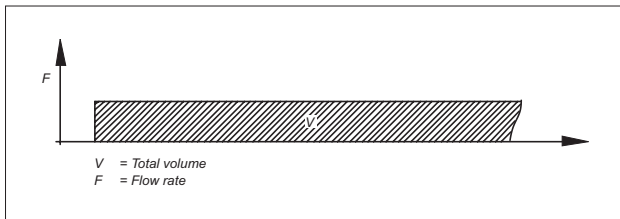

DISPENSE Mode

Dosing a definite volume, batches.

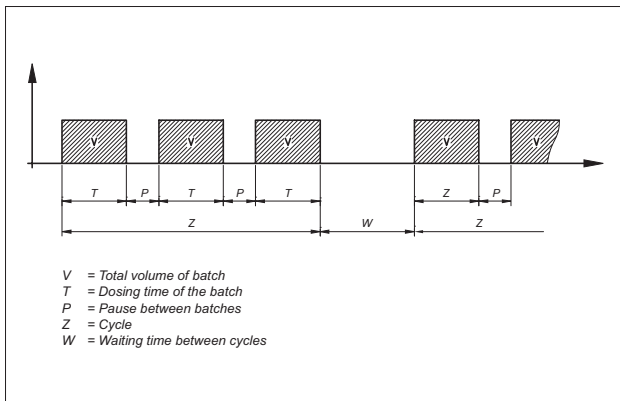

Flexible external controlling

For computer based systems there is a digital interface. With process applications the pump can be controlled with either an analog signal for a continual pumping action or by one or more impulses to start a predefined operating cycle.

Additional controlling possibilities can be made by using the two logic inputs and the floating relay switch.

Digital interface	RS 232, RS 485
Analog interface	0-20mA, 4-20mA, 0-5V, 0-10V
Logic controlling	I/O 1, I/O 2, Impulse (TTL)
Output signal	Floating relay switch

Technology with long-term precision

A flexible diaphragm is moved up and down by an eccentric which is connected to the motor shaft. During the downwards movement the liquid is sucked in through the inlet valve into the working chamber and by the upwards movement the liquid is pushed out through the outlet valve. The working chamber of the pump is hermetically separated from the motor so that the liquid can not be contaminated in any way.

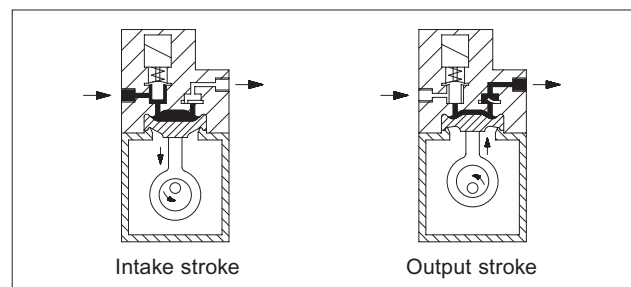

The stepper motor is controlled via the electronic module. The intake stroke is carried out at maximum speed and the output stroke is varied so that the liquid is dispensed evenly. This results in a quasi-continuous low pulsation flow.

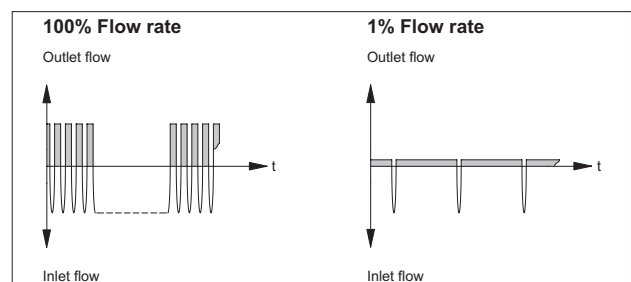

Materials of head components

Pump type	Head ¹⁾	Valves	Sealing gaskets	Diaphragm
FEM 1.03 / 1.08 KPRC	PP	EPDM	EPDM	PTFE-coated
FEM 1.03 / 1.08 KTRC	PP	FFPM	FFPM	PTFE-coated
FEM 1.03 / 1.08 TTRC	PVDF	FFPM	FFPM	PTFE-coated

¹⁾ PTFE and stainless steel on request

FEM 1.03-RC

FEM 1.08-RC



Performance

Basic model	Flow rate at atmos. pressure (ml/min)	Max. suction head (mWg)	Max. pressure head (mWg)
FEM 1.03-RC	0.03 - 30	4	60

Motor	3-Phase-stepper motor DC
Supply voltage	20 ... 28 V DC
Power rating	24 W
Max. power consumption	1 A
Noise level	< 40 dB
Motor protection class	IP 00
Nominal motor speed	180 rpm
Lifetime	> 10,000 h (10 ⁸ cycles)
Accuracy	+/- 2%
Repeatability	+/- 1%
Dosing range	1 : 1,000
Flow range	min. 30 µl/min - max. 30 ml/min
Volume, batch	50 µl ... 43.2 l 0.34 s ... 24 h
Allowed ambient temp.	+5 ... +40 °C
Allowed liquid temp.	+5 ... +80 °C
Max. viscosity	150 cSt
Connections	UNF 1/4"-28
Hose (OD)	1/8" - 1/32" (1.5 - 3.0 mm)
Weight	690 g

Performance

Basic model	Flow rate at atmos. pressure (ml/min)	Max. suction head (mWg)	Max. pressure head (mWg)
FEM 1.08-RC	0.08 - 80	3	40

Motor	3-Phase-stepper motor DC
Supply voltage	20 ... 28 V DC
Power rating	24 W
Max. power consumption	1 A
Noise level	< 40 dB
Motor protection class	IP 00
Nominal motor speed	180 rpm
Lifetime	> 10,000 h (10 ⁸ cycles)
Accuracy	+/- 2%
Repeatability	+/- 1%
Dosing range	1 : 1,000
Flow range	min. 80 µl/min - max. 80 ml/min
Volume, batch	80 µl ... 115.2 l 0.34 s ... 24 h
Allowed ambient temp.	+5 ... +40 °C
Allowed liquid temp.	+5 ... +80 °C
Max. viscosity	150 cSt
Connections	compression fittings 4/6
Hose (ID/OD)	4/6 mm
Weight	690 g

FEM 1.03-RC

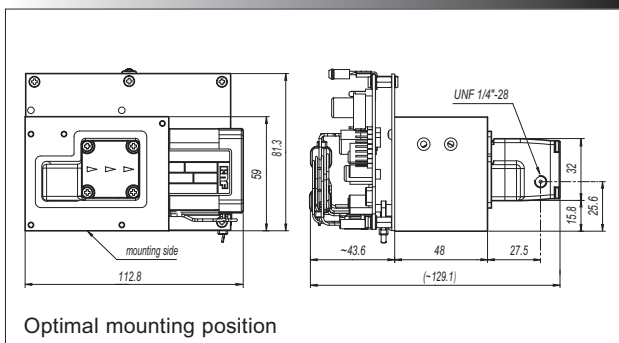

FEM 1.08-RC

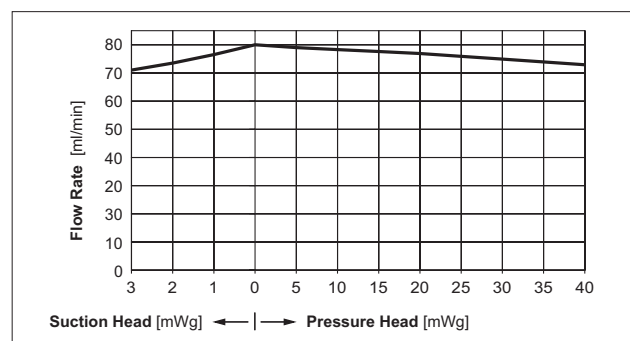
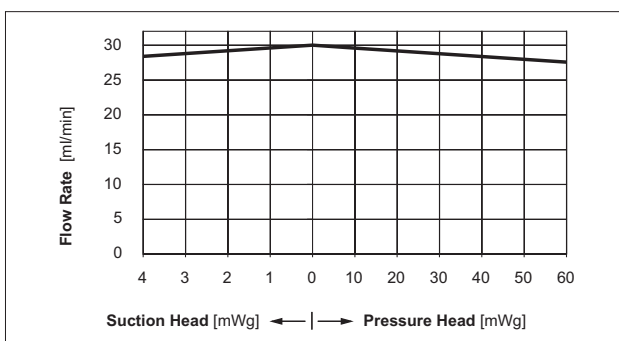
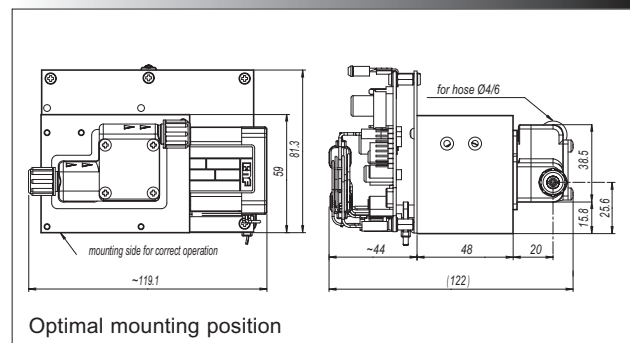

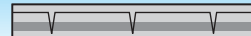

For the FEM 1.03/1.08 product series we offer a wide range of special variations. Individual problem solutions are our strength so please feel free to contact us if our standard product does not fulfil your requirements.

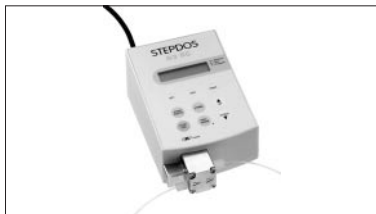

Laboratory version

For use in exposed areas we have built the FEM 1.03/1.08 pump into an IP65 housing with integrated transformer, keypad and display.

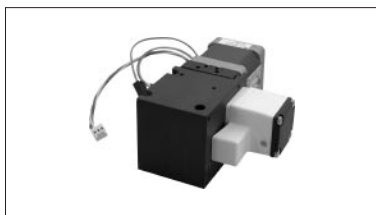

Pump with 2-phase stepper motor

When all of the features of our pump are not required (eg. compensated linearity of the diaphragm movement) we can offer a version with a 2-phase stepper motor. This includes the pump the motor and a solenoid valve but the electronics and programming must be provided by the customer.



Starter Kit including Windows® compatible software

The starter Kit comprises of a Keypad, various cables and the pump software.

This is required for:

- Configuring the electronics
- Testing and servicing
- Calibrating and initialising the pump

Accessories

- Software
- Hose set
- Filters
- Connectors
- Footswitch
- Cable for PC Connection (RS 232)
- Cable 5-pole for external controlling
- Pulsation damper
- Pressure relief valves and check valves

Further options

- Head materials (PTFE, Stainless steel)
- FEM 1.08 with UNF ¼"-28 or M5 inside threads

KNF FLODOS AG, Wassermatte 2, 6210 Sursee, Switzerland

Telephone +41 (0)41 925 00 25, Fax +41 (0)41 925 00 35

www.knf-flodos.ch, info@knf-flodos.ch

INNOVATIVE
TECHNOLOGY
WORLDWIDE

