

DIAPHRAGM PULSATION DAMPER FPD 06 / 1.06 / 10 / 1.10

DATA SHEET E 765

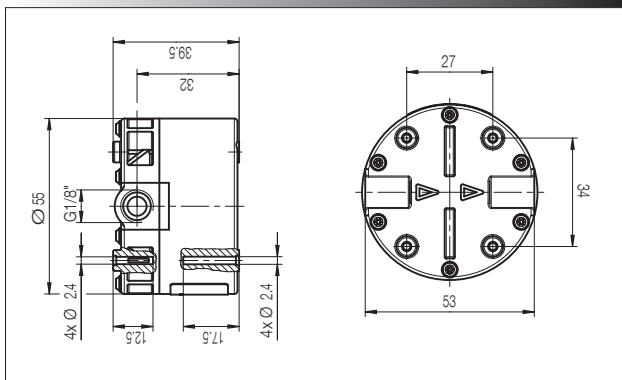

FPD 06/1.06-Z



FPD 10/1.10-Z

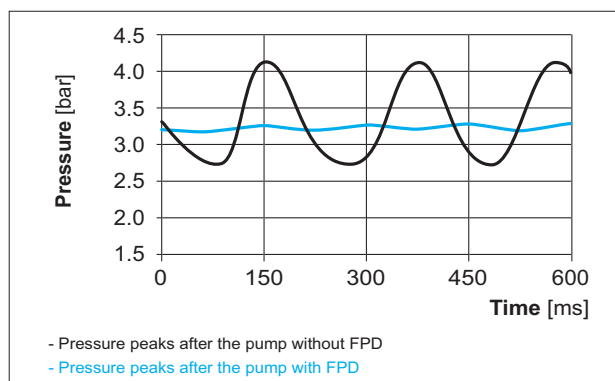
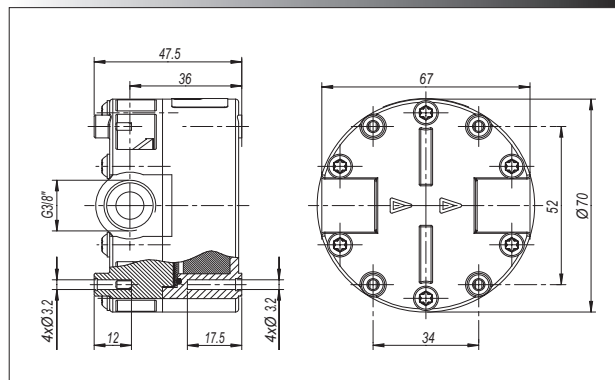

Concept

The KNF diaphragm pulsation damper can effectively reduce the pulsation after the pump by up to 97%, whereby it is important to note that the type of pulsation damper selected and the correct installation are essential in ensuring an optimal performance.

The pulsation damper is made up of only a few parts and is constructed in a simple but effective way. A diaphragm separates the liquid section (upper part) from the damping chambers (lower part). The damping elements (situated in the damping chambers) combined with the separating diaphragm remove a large part of the pulsation caused by the pump. In the upper part of the pulsation damper there are also two choke orifices which aid the damping process.

Features

High chemical resistance

The use of chemically resistant materials such as PP, PVDF, PTFE, FFPM or other material combinations for the parts which come in contact with the liquid allows almost all neutral or corrosive liquids to be pumped.

Durable and maintenance free

The carefully considered design of this very compact pulsation damper ensures safe operation and a long life even under the most severe conditions.

Areas of use

The KNF diaphragm pulsation damper is very versatile thus allowing it to be used not only in conjunction with a KNF pump, but in many general situations where less pulsation is required.

The pulsation damper can be used in the following areas:

- To reduce the vibration in hoses and pipes.
- To help remove pulsation which is preventing the system from functioning correctly.
- The protection of instrumentation connected after the pump.

The KNF Modular Concept of Selection



Our versatile self-selection program allows you to personally determine the optimum characteristics that you require from your pulsation damper. Select your diaphragm pulsation damper from the following characteristics:

KNF pump type being used	Max. allowed pressure (mWg)	Pulsation damper type			
		Basic model	Components		
			1	2	3
NF 10 / 30 / 60 / 100	██████████ 20	FPD 06		Z	
NF 1.30	██████████████████ 60*	FPD 1.06		Z	
NF 300	██████████ 20	FPD 10		Z	
NF 1.100 / 1.300	██████████████████ 60*	FPD 1.10		Z	

* For the KT and TT version: max. allowed system pressure = 40 mWg

1	Materials	
KP	Housing	PP
	Diaphragm	EPDM
KT	Housing	PP
	Diaphragm	FFPM
TT	Housing	PVDF
	Diaphragm	FFPM

3	Standard pulsation damper for the standard pump type
1	NF 30/60
2	NF 100
3	NF 1.30
4	NF 1.100
5	NF 300
6	NF 1.300
7	NF 10
0	Custom version

Selection and operation

- The KNF diaphragm pulsation damper has been constructed so that the remaining pulsation will be lower than 200 mbar. This value can be improved upon if the system parameters (system pressure, motor speed, etc.) are known.
- There is the possibility that the pulsation damper will increase the pressure after the pump. This should be taken into consideration when choosing the pump.
- The pulsation damper should be located as close as possible to the pump outlet. Long connection hoses between the pump and the pulsation damper can create vibrations.
- Also available with NPT thread.

KNF FLODOS AG, Wassermatte 2, 6210 Sursee, Switzerland
Telephone ++41 (0)41 925 00 25, Fax ++41 (0)41 925 00 35
www.liquidpumps.ch, info@knf-flodos.ch

