INNOVATIVE
TECHNOLOGY
WORLDWIDE



NEUBERGER

LABOPORT®

Operating Manual

CE



Chemically-resistant Laboratory Pumps with Modular Accessories

N 810 FT.18
N 820 FT.18
N 840 FT.18

N 810.3 FT.18
N 820.3 FT.18
N 840.3 FT.18

N 840.1.2 FT.18
N 842.3 FT.18

LABOPORT® Systems

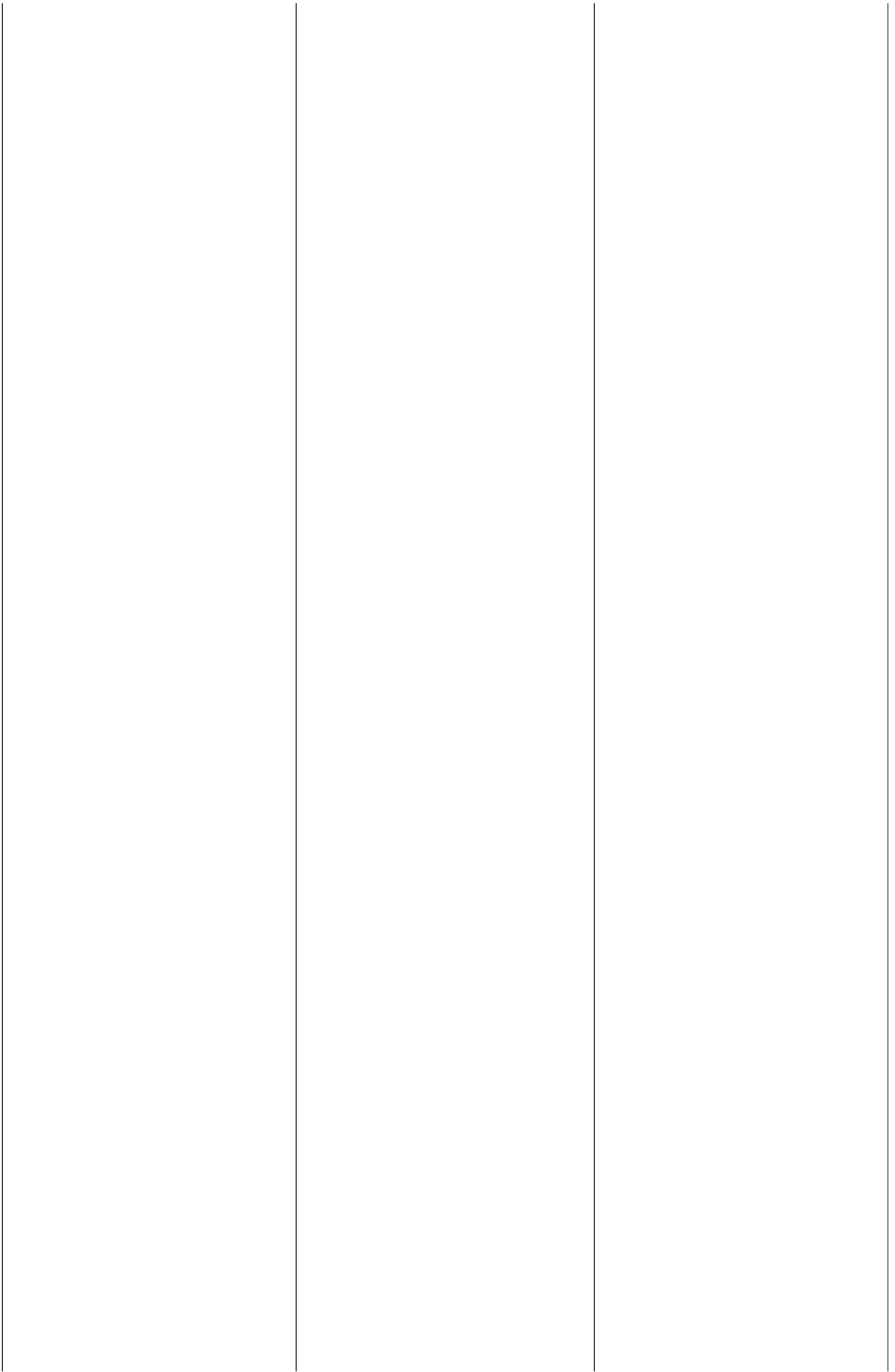

Carefully study the operating instructions before using a Laboport® pump or system and observe at all times the relevant instructions to avoid dangerous situations.

Table of Contents		Page
1	Description	4
1.1	Variable Options	4
1.1.1	Vacuum Pump with two Separators (SR...)	4
1.1.2	Vacuum Pump with Separator and High Performance Condenser (SH...)	4
1.1.3	Vacuum Pump with Separator, High Performance Condenser and one Vacuum Controller (SC...)	4
1.1.4	Vacuum Pump with Separator, High Performance Condenser and two Vacuum Controllers (SCC...)	5
2	General Safety Precautions	5
3	Assembling or Upgrading your System	6
3.1	Mounting the pump to the Baseplate	6
3.2	Assembling a System with Baseplate and two Separators	6
3.3	Assembling a System with Baseplate, Separator and High Performance Condenser	7
3.4	Assembling a System with Baseplate, Separator, High Performance Condenser, Electrical Supply Unit and one Vacuum Controller	7
3.5	Assembling a System with Baseplate, Separator, High Performance Condenser, Electrical Supply Unit and two Vacuum Controllers	8
3.5.1	Existing system with Baseplate, Separator, Condenser	8
3.5.2	Existing system with Electrical Supply Unit, Support and one Vacuum Controller	9
3.6	Mounting of Gas Ballast (option for two-headed pumps)	10
4	Operating Instructions	10
4.1	General Notes	10
4.2	Operating conditions	10
4.3	Operation of the Pump System	11
4.3.1	Operation with Baseplate and two Separators	11
4.3.2	Operation with Baseplate, Separator and High Performance Condenser	11
4.3.3	Operation with Baseplate, Separator, High Performance Condenser, Electrical Supply Unit and one Vacuum Controller	11
4.3.4	Operation with Baseplate, Separator, High Performance Condenser, Electrical Supply Unit and two Vacuum Controllers	11
4.3.5	Gas Ballast Option	11
5	System Shutdown	12
6	Troubleshooting the System	12
6.1	Troubleshooting System without Vacuum Controller	12
6.2	Troubleshooting System with one Vacuum Controller	12
6.3	Troubleshooting System with two Vacuum Controllers	13
7	Changing the Pump Diaphragms and the Valve Plates/Sealings	13
8	Ordering Information	16
8.1	LABOPORT®-Vacuum Pumps	16
8.2	Replacement Parts	16
8.3	Accessories for the modular LABOPORT®-System	16
9	Specifications	17
	Appendix: Customer statement for repair service	19

These operating instructions are valid for all models of the chemically-resistant LABOPORT® vacuum pumps

N 810 FT.18
N 820 FT.18
N 840 FT.18
N 810.3 FT.18
N 820.3 FT.18
N 840.3 FT.18
N 840.1.2 FT.18
N 842.3 FT.18

and LABOPORT®-systems:
SR..., SH..., SC... und SCC...

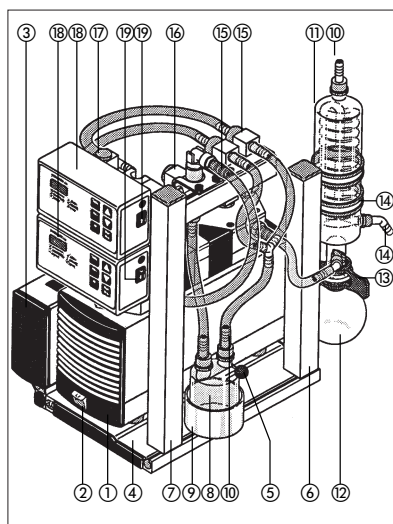

Figure 1: Full expanded LABOPORT® System SCC..., for example pump model N 840.3 FT.18 (symbolic)

Item	Description
①	Vacuum Pump
②	On/off switch of pump
③	Electrical Supply Unit
④	Baseplate
⑤	Locating pin for pump
⑥	Support for Condenser
⑦	Support for Vacuum Controller
⑧	Separator
⑨	Holder for Separator
⑩	Hose connector
⑪	High Performance Condenser
⑫	Flask for condensate
⑬	Spring Clamp
⑭	Angled nozzle for cooling water
⑮	Vacuum Valve
⑯	Pump Vent Valve
⑰	Valve unit at Vacuum Controller
⑱	Vacuum Controller
⑲	On/off switch of Vacuum Controller

1. Description

The LABOPORT® vacuum pump series was developed by KNF specifically to satisfy the exacting standards, reliability and ease of use demanded in today's laboratory applications.

KNF diaphragm pump technology has proved itself during recent decades and the LABOPORT® range is a logical continuation of this technology.

With eight vacuum pumps and facilities for modular expansion, a LABOPORT® pumping system can be optimised for any application.

Example of uses:

- Vacuum filtration
- Vacuum distillation
- Vacuum drying
- Impregnation
- Rotary evaporation
- Pumping and transferring of gases
- Gel drying.

Characteristics of the LABOPORT® FT pumps and the LABOPORT®-systems:

- The vacuum pumps are gas-tight, 100 % oil-free, maintenance-free and quiet.
- All parts of the pump head in contact with gases being pumped are resistant against aggressive substances (materials: PTFE, FFKM, PVDF).
- New valve system is very tolerant of water vapour and condensates.
- Illuminated switch on pump.
- Over-load protection by means of thermal switch.
- Compact design with space saving dimensions.
- Changing of the diaphragms and valves in the vacuum pumps is a simple procedure.
- The individual system components are easily integrated into one unit which can be progressively expanded up to the model SCC (with two Vacuum Controllers).
- The entire unit is mounted on a sturdy baseplate which makes it safe and easy to transport.
- Individual components are easily removed because they all have plug in connectors.
- All models designated SC with separator, high performance condenser and Vacuum Controller have plug in electrical connections to the Electrical Supply Unit

- Additional laboratory equipment can easily be mounted on the grooves holding the separator or on the support rods and horizontal bars.

1.1 Variable Options (ready to use)

Each of the designated pump systems types SR, SH and SC can be upgraded as required with modular components. The ultimate type is the SCC system which is capable of controlling two separate vacuum processes.

- ▶ Note: Starting with the pump it is possible to build up to each of the systems. See section 3.

1.1.1 Vacuum Pump with two Separators (System SR...)

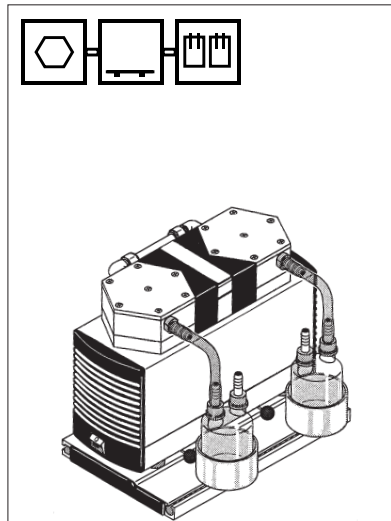

Figure 2: LABOPORT® system SR, for example pump model N 840.3 FT.18

Condensable components in the gas can be separated on the exhaust side of the pump in order to prevent their escape into the environment. On the suction side the Separator collects any particular matter and droplets. This protects the pump from contamination and ensures maximum performance of the pump.

The Separator is made of a specially treated glass and features implosion protection.

1.1.2 Vacuum Pump with Separator and High Performance Condenser (System SH...)

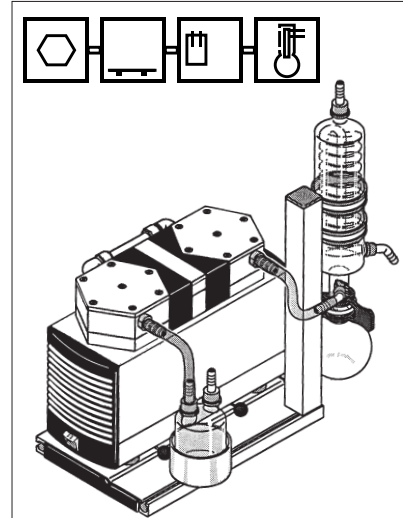

Figure 3: LABOPORT® system SH, for example pump model N 840.3 FT.18

The High Performance Condenser enables condensable components in the vapour to be separated out and hereby removed from the atmosphere and at the same time protecting the environment.

The condensate is collected in a glass flask. The flask is attached to the Condenser flange with a clamp. The condensation temperature is maintained by running cold water or recirculated coolant through the Condenser.

- ⚠ The Condenser must be installed on the outlet side of the pump; if it is installed on the inlet side there is a danger of implosion.

1.1.3 Vacuum Pump with Separator, High Performance Condenser and one Vacuum Controller (System SC...)

Vacuum pumps in conventional laboratory systems operate continuously even after they reach their final vacuum level. LABOPORT® systems equipped with a Vacuum Controller enable the pump to be switched on and off between pre-set vacuum levels. Setting of the vacuum levels and differential pressure is effected via a keypad on the Vacuum Controller.

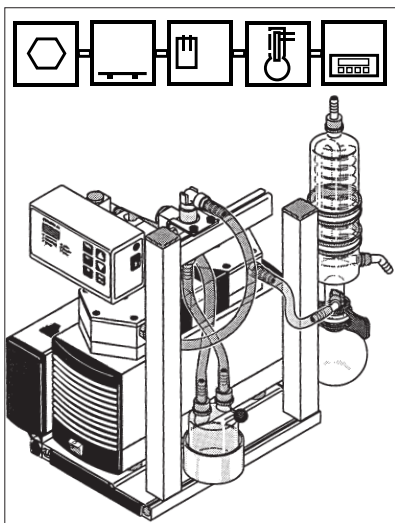

Figure 4: LABOPORT® system SC, for example pump model N 840.3 FT.18 (symbolic)

Features of the Vacuum Controller

- Simple entry of the desired vacuum level and differential pressure.
- Precise reproducibility of set values.
- Facility to interrupt pumping program at any point.
- The LABOPORT® system with Vacuum Controller automatically vents to atmosphere when switched off. This prolongs the operating life of the pump.
- Easy venting of the system at a touch of the key pad.
- One touch resetting from controlled pumping to maximum vacuum.
- In the event of power failure the last entered values are retained.

⚠ For LABOPORT System with vacuum controller or vacuum controllers:

The system must not be used if the entry of air or gas into the vacuum system during venting could result in the creation of reactive, explosive or otherwise hazardous mixtures (e.g. with the medium).

1.1.4 Vacuum Pump with Separator, High Performance Condenser and two Vacuum Controllers (System SCC...)

By adding a second Vacuum Controller two separate pumping applications may be carried out simultaneously and independently, using only one vacuum pump.

⚠ Within the system only simultaneously use those gases which can be mixed safely.

⚠ For LABOPORT System with vacuum controller or vacuum controllers:

The system must not be used if the entry of air or gas into the vacuum system during venting could result in the creation of reactive, explosive or otherwise hazardous mixtures (e.g. with the medium).

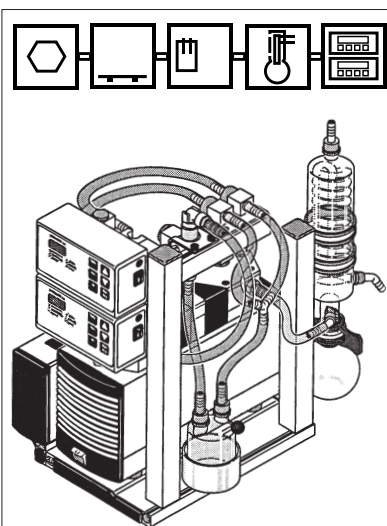

Figure 5: LABOPORT® system SCC, for example pump model N 840.3 FT.18 (symbolic)

2. General Safety Precautions

⚠ Observe all applicable accident prevention regulations as well as generally recognised Health & Safety rules.

- Carefully study the operating instructions before using a LABOPORT® pump or system and observe at all times the relevant instructions to avoid dangerous situations.
- Always keep the operating manual handy in the work area.
- Ensure that the pump system and its components are used only for those applications for which they were intended.
- Plug the machine only into properly installed grounded outlets.

⚠ All pump models are fitted with protective thermal switches. After operation of the thermal switch or after a power failure the unit must be disconnected from the mains to avoid uncontrolled restarting of the pump.

⚠ The pump/the LABOPORT®-system must not be used in areas where there is the danger of explosion.

⚠ For LABOPORT System with vacuum controller or vacuum controllers:

The system must not be used if the entry of air or gas into the vacuum system during venting could result in the creation of reactive, explosive or otherwise hazardous mixtures (e.g. with the medium).

⚠ Gas ballast (optional) must not be used if the entry of air into the pump could result in the creation of reactive, explosive or otherwise hazardous mixtures (e.g. with the medium).

- Parts of the casing marked with the sign below are only allowed to be opened after pulling out the plug (disconnecting the power source).

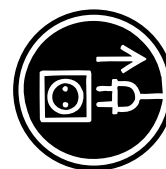

- Only authorized personnel should open those parts of the casing that contain live electrical parts.
- When cleaning the unit make sure that no fluids come into contact

with the inside of the casing.

- Use only original KNF replacement parts.
- Do not expose any part of your body to the vacuum.

⚠ Observe the specific safety precautions in section 4 Operating Instructions.

3. Assembling or Upgrading your System

3.1 Mounting the pump to the Baseplate (all systems)

Basic requirements for the assembly of a LABOPORT® system are a LABOPORT® pump and a Baseplate. The mounting-system allows interchange of pump types on the baseplate without difficulties.

For mounting a LABOPORT®-pump to the baseplate the pump must be equipped with a mount (two elements).

Pumps ordered as part of a LABOPORT®-system are already equipped with these mounts. Baseplates ordered separately (see 8.3 Accessories for the LABOPORT®) will also contain the mounts. Installation of the mounts on the pump:

Mounting the pump to the Baseplate:

- ① Unscrew the pump's rubber feet anti-clockwise.
- ② Install the mounts onto the pump according to figure 6.

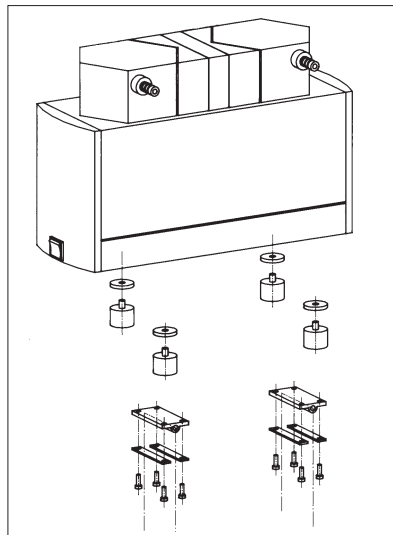

Figure 6: Installation of the mounts at the pump

Mounting the pump to the Baseplate:

- ① Stand the pump (fitted with the mounts) onto the Baseplate and align the mounts on the pump and the Baseplate.
- ② Carefully slide the locating pin through the mount holes on the Baseplate and on the pump until they are fully engaged.
- ③ Check that the pump is securely fastened to the Baseplate via both shock mounts.

- Before interchanging pumps the pump on the Baseplate must be unplugged from the electrical power.

3.2 Assembling a System with Baseplate and two Separators

Baseplate: see 3.1

Separator

Required tool:

- Philips-head screwdriver Nr. 3
- ① Slide in the holders for the Separators into the Baseplate mounting slot.
 - ② Fix the holders by tighten the screws in the bottom of them.
 - ③ Place the glass Separators into the holders.
 - ④ Tubing of two-headed pumps: see figure 7. For tubing of single-headed pumps and pumps with aluminum heads (pump types including an „A” in the type code), please contact KNF. Choose tube material which is resistant against the media to be used.

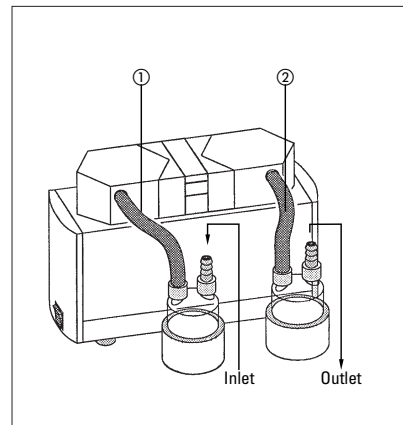

Figure 7: Tubing system SR... (two-headed pumps)

SR-Tubing of two headed pumps:

- ① Approx. Tube length 150 mm
- ② Approx. Tube length 150 mm
- ①-② Tube-inside diameter 10 mm

- The rubber hoses on the attachment nozzles can be freely exchanged.

3.3 Assembling a System with Baseplate, Separator and High Performance Condenser

Baseplate: see 3.1

Separator: see 3.2

Condenser:

- In order to operate properly the High Performance Condenser requires a cold water connection or recirculated cooling system.
- ⚠ The Condenser must be installed on the outlet side of the pump; if it is installed on the inlet side there is a danger of implosion.
- The condenser is already attached to the Support.

Required tool:

- Allen key 5 mm
- ① Slide the support (more exactly: its clamp assembly) into the end of the Baseplate Mounting Slot (positioning as shown in figure 1).
- ② Fix the Support to the Baseplate by tightening the Allen screw on the Support.
- ③ Tubing of two-headed pumps see figure 8. For tubing of single-headed pumps and pumps with aluminum heads (pump types including an „A“ in the type code), please contact KNF. Choose tube material which is resistant against the media to be used.

⚠ Ensure that the vapour outlet on the top of the Condenser is not blocked e.g. due to kinks in the rubber tubing (danger of pressure build-up).

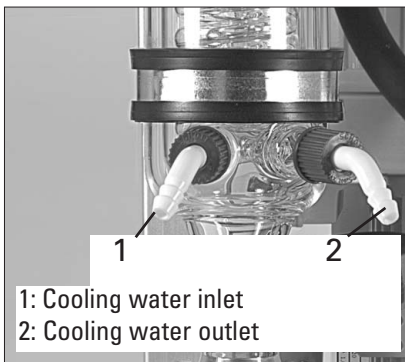

Fig. 9: Cooling water supply of condenser

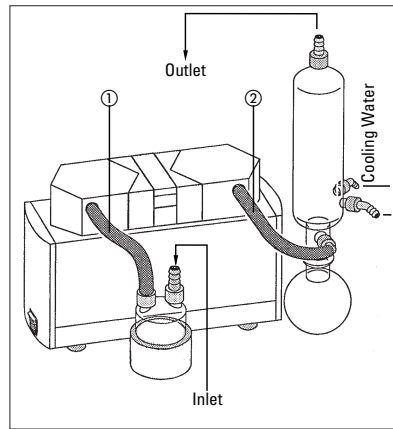

Figure 8: Tubing system SH... (two-headed pumps)

SH-Tubing of two headed-pumps :

- ① Approx. Tube length 150 mm
- ② Approx. Tube length 220 mm
- ①-② Tube-inside diameter 10 mm

⚠ Observe the correct usage of the gas- and cooling water-connections on the condenser (see figure 8). Inlet and outlet connections for the vapour side are not interchangeable.

- When connecting the tubing, make sure that the pump's exhaust nozzle is always higher than the Condenser's inlet connection. This prevents any condensate that might form in the tube from running back into the pump head in large quantities.
- Cooling water supply of condenser see figure 9.
- The condenser-connectors for the cooling water require connection tubing with an inside diameter of 8 mm.

3.4 Assembling a System with Baseplate, Separator, High Performance Condenser, Electrical Supply Unit and one Vacuum Controller

Baseplate: see 3.1

Separator: see 3.2.

Condenser: see 3.3.

Vacuum Controller/ Electrical Supply Unit

See also figure 1.

Required tools:

- Allen key 4 mm
- Allen key 5 mm
- ▽ Vacuum Controller, Controller Vent Valve and Pump Vent Valve are

already attached to the Vacuum Controller Support.

Mounting the Electrical Supply Unit to the Baseplate:

The Electrical Supply Unit consolidates all of the electrical connections for the system and also controls the pump.

- ① Slide the Electrical Supply Unit (more exactly: its clamp assemblies) into the Baseplate Mounting Slot.
- ② Fix the unit by tightening the two Allen screws at the bottom of the Electrical Supply Unit.

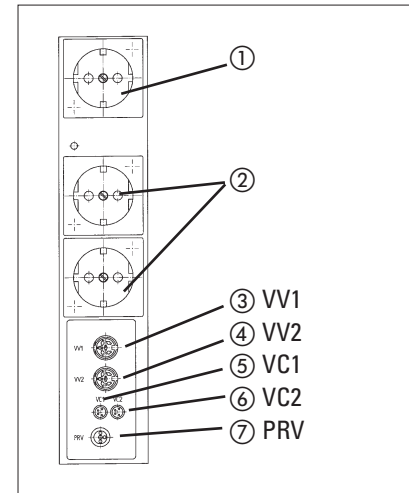

Fig. 10: Connections of the Electrical Supply Unit (Systems SC..., SCC...)

- ① switched safety socket for pump
- ② two safety sockets for Vacuum Controller NC 800

Control-print

- ③ for Vacuum Valve 1
- ④ for Vacuum Valve 2 (only if system is operated with two Vacuum Controllers)
- ⑤ for connecting wire of Vacuum Controller 1
- ⑥ for connecting wire of Vacuum Controller 2 (only if system is operated with two Vacuum Controllers)
- ⑦ for Pump Vent Valve

Mounting the Vacuum Controller and Valve Assembly

- ③ Slide the Support for the Vacuum Controller (more exactly: its clamp assembly) into the Baseplate Mounting Slot (orientation: see figure 4).
- ④ Fix the Support to the Baseplate by tightening the Allen screw on the Support.

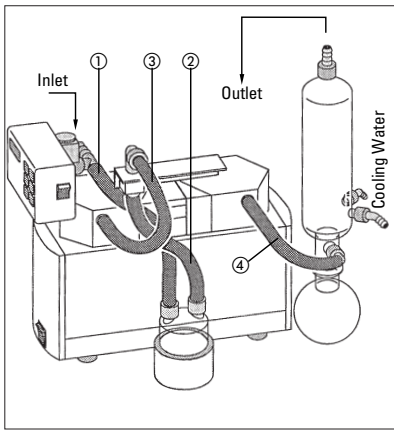

Fig. 11: Tubing System SC...
(two-headed pumps)

SC-Tubing of two-headed pumps:

- ① Approx. Tube length 220 mm
- ② Approx. Tube length 150 mm
- ③ Approx. Tube length 300 mm
- ④ Approx. Tube length 220 mm
- ①-④ Tube-inside diameter 10 mm
- ⑤ Tubing of two-headed pumps: see figure 11. For tubing of single-headed pumps and pumps with aluminum heads (pump types including an „A“ in the type code), please contact KNF. Choose tube material which is resistant against the media to be used.

Electrical Connection:

- See also figures 9 and 12.
- ⑥ Connect signal socket of the Vacuum Controller (on the rear) with the Electrical Supply Unit socket marked VC 1 using the connection cable.
- ⑦ Insert the Vacuum Controller power cord plug into the designated Electrical Supply Unit socket.
- ⑧ Insert the Pump Vent Valve plug

into the Electrical Supply Unit socket marked PRV.

- ⑨ Insert the vacuum pump power cord plug into the designated Electrical Supply Unit socket.
- ▶ To ensure the correct function of the system the mains connection of the pump must be plugged into this designated socket.
- ⑩ Neatly tuck all of the wires into the Electrical Supply Unit and secure the cover.
- ⑪ Be sure all power switches (on the pump and on the Vacuum Controllers) are switched off. Insert the Electrical Supply Unit's system power cord plug into a suitably installed safety socket.

▽ **Option:**
Cooling Water Valve

If the regulation mode of the LABO-PORT®-system is interrupted or brought to an end by pressing the "Start/Stop" key, normally the cooling water for the condenser does not stop running. By using a cooling water valve the water is stopped.

Mounting the cooling water valve:

- ① Install the cooling water valve at the water supply.
- ⚠ The cooling water valve must on no account be installed in the water drain line, or behind the condenser (danger of pressure build-up in Condenser).
- ② Insert the connecting cable plug of the cooling water valve into the Vacuum Controller socket marked VV 1.

3.5 Assembling a System with Baseplate, Separator, High Perfor-

mance Condenser, Electrical Supply Unit and two Vacuum Controllers

Following the necessary steps for upgrading an existing LABO-PORT®-system to the ultimate system is described for two starting points:

- ▶ Existing system with Baseplate, Separator and high performance Condenser; upgrading with Accessory **NC 800 A/B** see **section 3.5.1**
- ▶ Existing system with Baseplate, Separator, high performance Condenser, Electrical Supply Unit, Support for Vacuum Controller and one Vacuum Controller; upgrading with Accessory **NC 800 B** see **section 3.5.2**

3.5.1 Existing system with Baseplate, Separator, Condenser

- See also figure 1.

Required tools:

- Allen key 4 mm
- Allen key 5 mm

▽ Both Vacuum Controllers, the Controller Vent Valves, the Pump Vent Valve and the Vacuum Valves are already attached to the Support for the Vacuum Controller.

- ① Shut down the system (see section 5) (pull out the pump power plug).

Mounting the Electrical Supply Unit to the Baseplate:

- ② Slide the Electrical Supply Unit (more exactly: its clamping assemblies) into the Baseplate Mounting Slot.
- ③ Fix the unit by tightening the two Allen screws at the foot of the Electrical Supply Unit.

Mounting the Vacuum Controller Support to the Baseplate:

- ④ Slide the Vacuum Controller Support (more exactly: its clamping assembly) into the Baseplate Mounting Slot (orientation: see figure 5).
- ⑤ Fix the Vacuum Controller Support by tightening the Allen screw at the foot of the Support.

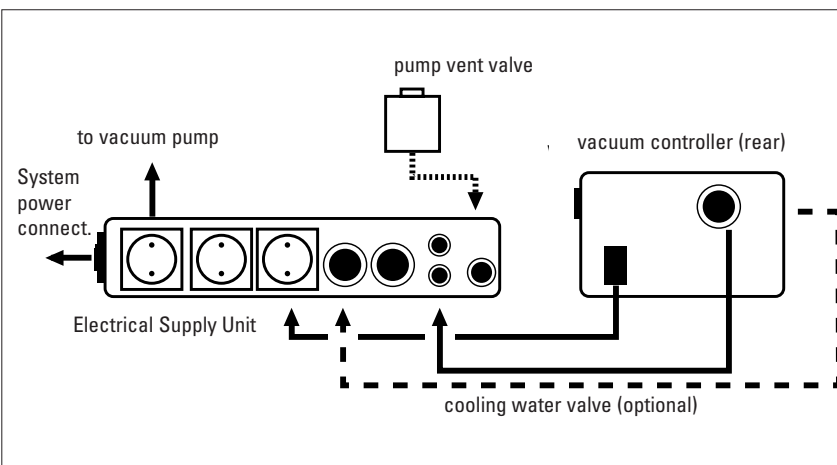

Fig. 12: Electrical Connections SC...

Tubing:

- 6 Tubing of two-headed pumps: see figure 13. For tubing of single-headed pumps and pumps with aluminum heads (pump types including an „A“ in the type code), please contact KNF. Choose tube material which is resistant against the media to be used.

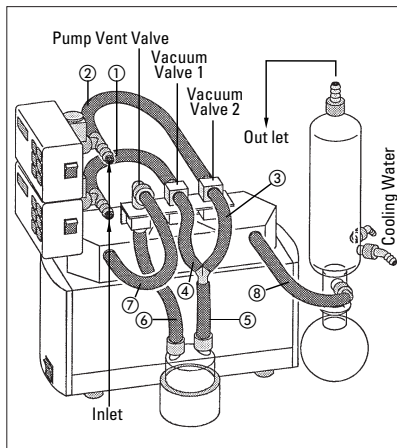

Fig. 13: Tubing System SCC...
(two-headed pumps)

SCC-Tubing of two-headed pumps:

- 1 Approx. Tube length 320 mm
- 2 Approx. Tube length 260 mm
- 3 Approx. Tube length 120 mm
- 4 Approx. Tube length 120 mm
- 5 Approx. Tube length 135 mm
- 6 Approx. Tube length 175 mm
- 7 Approx. Tube length 350 mm
- 8 Approx. Tube length 220 mm
- 1-8 Tube-inside diameter 10 mm

Electrical Connections:

- See figures 9 and 14.
- 7 For both Vacuum Controllers:

Connect signal socket of the Vacuum Controller (on the rear) with the Electrical Supply Unit socket marked VC 1 and VC 2 using the connection cable.

- 8 Insert the Vacuum Controllers power cord plugs into the Electrical Supply Unit sockets.
- 9 Insert the plugs from the both Vacuum Valves into the Electrical Supply Unit sockets marked VV 1 and VV 2.
- 10 Insert the plug from the Pump Vent Valve into the Electrical Supply Unit socket marked PRV
- 11 Insert the Vacuum Pump plug into the power socket inside the Electrical Supply Unit marked Pump Power Controller
- To ensure the correct function of the system the mains connection of the pump must be plugged into this designated socket
- 12 Neatly tuck all of the wires into the Electrical Supply Unit and secure the cover.
- 13 Be sure all power switches (pump, Vacuum Controllers) are off. Plug the Electrical Supply Unit's system power cord plug into a suitably installed safety socket.

3.5.2 Existing system with Electrical Supply Unit, Support and one Vacuum Controller

- See also figure 1

Required tool:

- Allen screw 4 mm

- ▽ Second Vacuum Controller including Controller Vent Valve is already attached to the new Support for the Vacuum Controller (length: 410 mm).

Dissassembly:

- 1 Shut down the system (see section 5) (pull out the Electrical Supply Unit power plug)
- 2 Disconnect the tubes from the Pump Vent Valve as well as from the Controller Vent Valve
- 3 Pull out all plugs from the Electrical Supply Unit
- 4 Remove the Vacuum Controller from the Support after loosening the clamp assembly
- 5 Remove the Valve Support from the Controller Support after loosening the clamp assembly
- 6 Remove the Controller Support from the Baseplate:
 - a. Loosen the Allen screw at the foot of the Vacuum Controller Support.
 - b. Slide it out of the Baseplate Mounting Slot Assembly.
- 7 Mount the existing Vacuum Controller onto the new Controller Support: Slide the Vacuum Controller (more exactly: its clamping assembly) into the Vacuum Controller Support Mounting Slot and fix the Vacuum Controller by tightening the Allen screw.
- 8 Slide the Vacuum Controller Support (more exactly: its clamping assembly) into the Baseplate Mounting Slot.
- 9 Fix the Vacuum Controller Support by tightening the Allen screw at the foot of the Support.
- 10 Mount the Valve Support onto the Vacuum Controller Support.
- 11 Slide the holding device for the Vacuum Valves (including Vacuum Valves) onto the Valve Support Mounting Slot and fix the device with help of the clamping assembly.
- 12 Tubing of two-headed pumps: see figure 13. For tubing of single-headed pumps and pumps with aluminum heads (pump types including an „A“ in the type code), please contact KNF. Choose tube material which is resistant against the media to be used.
- 13 Electrical connection: see section 3.5.1.

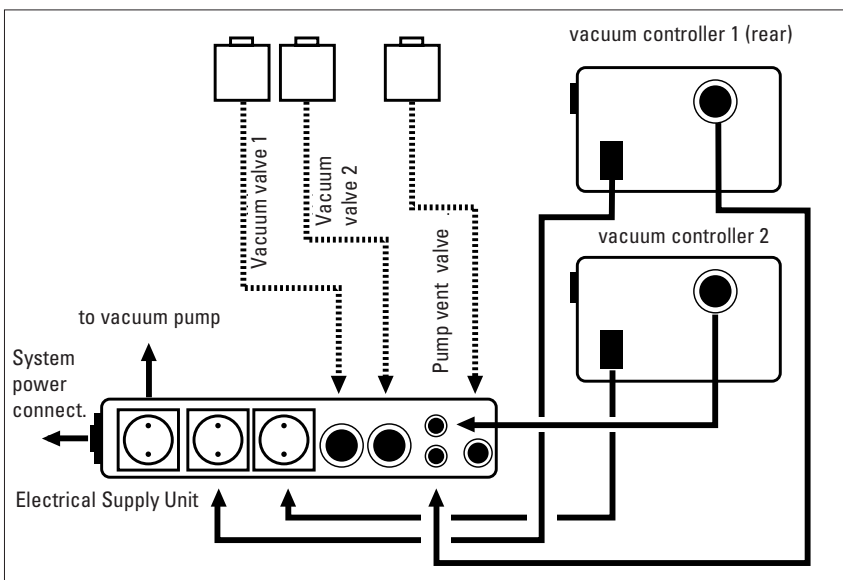

Fig. 14: Electrical Connections SCC...

3.6 Mounting of Gas Ballast (option for two-headed pumps)

- ① Shut down the system (see section 5) (pull out the pump power plug and the Electrical Supply Unit power plug).
- ② Disconnect the tubes from the inlet and the outlet of the pump.
- ③ Remove the pump from the Baseplate.
- ④ Open the connection of the pump heads (see figure 15).
- ⑤ Screw out the connecting piece of the vacuum side head (see figure 15).
- ⑥ Screw the Gas Ballast into the pump head (the connecting piece of the gas ballast is sealed with Teflon-tape).
- ⑦ Remount the connection between the both pump heads.

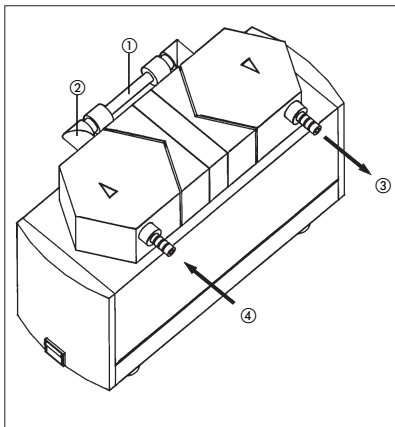

Fig. 15: Mounting the Gas Ballast

- ① Connection
- ② Connecting piece of the vacuum side head
- ③ **Outlet**
- ④ **Inlet (Vacuum side)**

4 Operating Instructions

4.1 General Notes

Before using the vacuum pump or the LABOPORT®-system please observe the following points:

- Choose a safe location (flat surface) for the equipment.
 - Ensure that the vacuum pump is securely fastened to the Baseplate. The two locating pins underneath the pump must be locked in position.
 - Remove protective plugs from pneumatic connections of the pump and (only for systems SC and SCC) from back of the Vacuum Controller.
- ⚠ Laboratory equipment or additional components connected to a LABOPORT®-pump or a LABOPORT®-system have to be suitable for use with the pneumatic capabilities of the pump.
- When using the High Performance Condenser the system must be connected to a cold water supply or a recirculating cooler.
 - The High Performance Condenser is designed for coolants with pressure up to 3 bar g and temperatures between - 15 ... + 20 °C.
- ⚠ The pump/the LABOPORT®-system must not be used in areas where there is the danger of explosion.

Before getting started:

- ⚠ Specific safety instructions for the media being handled must be observed.
- ⚠ For LABOPORT System with vacuum controller or vacuum controllers:
- The system must not be used if the entry of air or gas into the vacuum system during venting could result in the creation of reactive, explosive or otherwise hazardous mixtures (e.g. with the medium).
- Prior to any use of the vacuum system, ensure that the creation of reactive, explosive or otherwise hazardous mixtures during the supply of air is prevented.
- ⚠ Gas ballast (optional) must not be used if the entry of air into the pump could result in the creation of reactive, explosive or otherwise hazardous mixtures (e.g. with the

medium).

Prior to any use of the pump with gas ballast, ensure that the creation of reactive, explosive or otherwise hazardous mixtures during the supply of air is prevented.

- ⚠ Ensure the pump outlet is not closed or restricted.
- ⚠ If using a Condenser: Make sure that the vapour outlet on the top of the Condenser is never blocked (a kink in the exhaust hose could cause pressure build up).

Check:

- ① All clamping connections for tightness.
 - ② Tubing for correct connection.
 - ③ Electrical connections for correct connection.
- Be sure to connect the pump to the correct electrical power supply as specified on the vacuum pump.

4.2 Operating conditions

General operating conditions of the pump and system (including Electrical Supply Unit and Vacuum Controller):

- Permissible ambient temperature: + 5... + 40 °C.
- ⚠ The pump/the LABOPORT®-system must not be used in areas where there is the danger of explosion.
- Protect pump and system against humidity.

Additional operating conditions of the pump:

- Liquids must not be pumped.
 - Permissible temperature of gas to be pumped: + 5...+ 40 °C.
 - Do not start the pump with excess pressure on the exhaust side.
 - If the pump stops e.g. due to power failure the pump has to be vented manually. Pump systems using a Vacuum Controller will automatically vent through the Pump Vent Valve.
- ⚠ Gas ballast (optional) must not be used if the entry of air into the pump could result in the creation of reactive, explosive or otherwise hazardous mixtures (e.g. with the medium).
- Prior to any use of the pump with gas ballast, ensure that the crea-

tion of reactive, explosive or otherwise hazardous mixtures during the supply of air is prevented.

- The quantity of air or gas should be controlled or throttled only on the suction side of the pump. If control is needed on the exhaust side, do not exceed the designated maximum pressure of the respective pump.
- The ventilation openings on the pump must not be obstructed to ensure sufficient cooling for the motor.
- The pump can operate continuously even after final vacuum level is attained.

Additional operating conditions for LABOPORT systems with High Performance Condensers:

- The High Performance Condenser is designed for coolants with pressure up to 3 bar g and temperatures between - 15 ... + 20 °C.

Additional operating conditions for LABOPORT systems with vacuum controller or vacuum controllers:

- ⚠ The system must not be used if the entry of air or gas into the vacuum system during venting could result in the creation of reactive, explosive or otherwise hazardous mixtures (e.g. with the medium).
Prior to any use of the vacuum system, ensure that the creation of reactive, explosive or otherwise hazardous mixtures during the supply of air is prevented.

4.3 Operation of the Pump System

- The vacuum pump can be switched on and off using the power switch located below the ventilation inlet (see figure 1, item 2).
- LABOPORT®-systems with Vacuum Controller(s): Controller(s) can be switched on and off using the power switch.

4.3.1 Operation with Baseplate and two Separators

The Separator

- The holders which hold the Separators can be repositioned if necessary by loosening the screw and sliding them along the groove.

Emptying and cleaning of the Separator

- ① Unscrew the two connecting nozzles.
- ② Remove the Separator from the holder, empty and rinse.
- ③ Replace Separator into the holder.
- ④ Screw the attachment nozzles back on.

4.3.2 Operation with Baseplate, Separator and High Performance Condenser

Separator: see section 4.3.1

High performance Condenser

- ⚠ The Condenser must be installed on the outlet side of the pump; if it is installed on the inlet side there is a danger of implosion.
- ⚠ Ensure that the vapour outlet on the top of the condenser is not restricted. e.g. due to kinks in the tubing.

Emptying and cleaning the condenser

- ① Carefully remove the spring clamp while supporting the flask.
- ② Empty and clean the flask - observing safety precautions.
- ③ Re-connect the flask to the condenser and replace the spring clamp.

Adjustment of the Condenser altitude level

Required tool:

- Allen key 5 mm
- ① Loosen the both Allen screws at the foot of the Condenser.
 - ② Remove the Condenser clamp assembly in the Support Mounting Slot.
 - ③ Retighten the Allen screws.

4.3.3 Operation with Baseplate, Separator, High Performance Condenser, Electrical Supply Unit and one Vacuum Controller

Separator: see section 4.3.1

High performance Condenser: see section 4.3.2

Electrical Supply Unit

- The disconnection of the Electrical Supply Unit from the power source is achieved by pulling out the plug.

Vacuum Controller NC 800

See Operating Manual of Vacuum Controller.

4.3.4 Operation with Baseplate, Separator, High Performance Condenser, Electrical Supply Unit and two Vacuum Controllers

- ⚠ Within the system only simultaneously use those gases which can be mixed safely.

Separator: see section 4.3.1

High performance Condenser: see section 4.3.2

Vacuum Controller:

- A pump system with two Vacuum Controllers can control two separate processes simultaneously and independently. This is made possible by using two Vacuum Valves each controlled by one Vacuum Controller.
- Using each of the two Vacuum Controllers is the same as using one individually (see section 4.3.3). Each Vacuum Controller functions independently of the other and can be separately set.
- Once the preset vacuum level on one of the Vacuum Controllers has been reached, the Vacuum Valve that it controls will close. The pump, however, may continue to operate until the preset vacuum on the other Vacuum Controller is reached. The second Vacuum Valve then closes; the pump shuts off and the Pump Vent Valve opens.
- Once the pump has vented, it restarts only when one of the differential pressures exceeds the preset level.

4.3.5 Gas Ballast Option

Using the gas ballast option, increases the pump's gas pressure in order to prevent condensation build up.

- ⚠ Gas ballast (optional) must not be used if the entry of air into the pump could result in the creation of reactive, explosive or otherwise hazardous mixtures (e.g. with the

medium).

Prior to any use of the pump with gas ballast, ensure that the creation of reactive, explosive or otherwise hazardous mixtures during the supply of air is prevented.

▽ If the gas ballast valve is open the maximum achievable vacuum level is reduced.

■ Function of the operating knob: see figure 16.

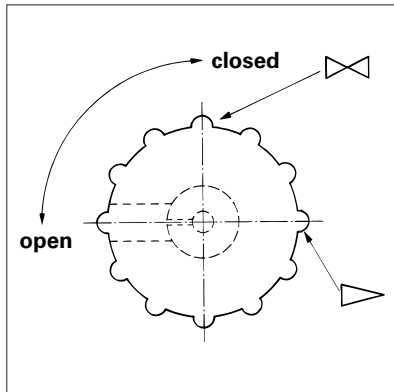

Fig. 16: Function of the gas ballast operating knob

5. System Shutdown

- 1 Clean the containers.
- 2 Purge the complete pump system including the connecting hoses with air for about 5 minutes.
- 3 Shut down the system power.
- 4 Disconnect the power source to the Electrical Supply Unit.

6. Troubleshooting the System

6.1 Troubleshooting System without Vacuum Controller

► Sufficient vacuum is not reached

Possible reasons:

- 1 Tube connections are not tight
- 2 Condensate in the pump head (detach the condensate source from the pump).
- 3 Diaphragms and/or valve plates/sealings are worn out (changing diaphragms and valve plates/sealings: see section 7).
- 4 If this problem occurs after changing of diaphragms and valve plates/sealings: see information in section 7.

► Pump is switched on, but does not run, the on/off-switch on the pump is not lit

Possible reasons:

- 1 Pump is not connected with the power source.
- 2 No voltage in the power source.
- 3 Fuse in the pump is defective (only authorized/qualified personnel should investigate this problem; disconnect the pump from the power source, the fuse is accessible after opening the marked cover at the bottom of the pump. Dimension of the fuse: see section 9).

► Pump is switched on, but does not run, the on/off-switch on the pump is lit

Possible reasons:

- 1 The thermal switch has opened due to overheating (disconnect the pump from the power source, let the pump cool down, investigate the reason for the overheating and irradiate it).

6.2 Troubleshooting System with one Vacuum Controller

► Sufficient vacuum is not reached

Possible reasons:

- 1 As for system without Vacuum Controller (see under section 6.1).
- 2 Additional possible reason: solid particles in the Pump Vent Valve.

- ③ If condensation occurs in the pump head, let the pump run to the ultimate vacuum (Drying Mode, see Operating Manual of Vacuum Controller).

- ▶ **Vacuum Controller is switched on and set on "Regulation Mode", the desired vacuum level is not reached, pump does not run, the on/off-switch on the pump is not lit**

Possible reasons:

- ① Pump is not switched on
- ② Incorrect electrical connection
- ③ Fuse in the pump is defective (see "System without Vacuum Controller", section 6.1).

- ▶ **Vacuum Controller is switched on and set on "Regulation Mode", the desired vacuum level is not reached, pump does not run, the on/off-switch on the pump is lit**

Possible reason:

- ① The thermal switch has opened due to overheating (disconnect the pump from the power source, let the pump cool down, investigate the reason for the overheating and irradiate it).

- ▶ **Vacuum Controller is switched on, no LED-indication**

Possible reasons:

- ① In the Electrical Supply Unit the Vacuum Controller plug is plugged into the socket for the pump.
- ② The fuse in the Vacuum Controller is defective (the fuse is located above the on/off-switch of the Vacuum Controller. Dimension of the fuse: see section 9).
- ③ The fuse in the Electrical Supply Unit is defect (the fuse is located at the end of Electrical Supply Unit below the mains connection. Dimension of the fuse see section 9).

- ▶ **Vacuum Controller shows unrealistic values**

Possible reasons:

- ① The Vacuum Controller requires recalibrating (contact KNF).
- ② The sensor is defective (contact KNF).

6.3 Troubleshooting System with two Vacuum Controllers

- See system with one Vacuum Controller (section 6.2).
- ▶ **System does not work, despite one Vacuum Controller (both controllers) being set on "Regulation Mode"**

Possible reasons:

- ① In the Electrical Supply Unit the connecting wires for the Vacuum Controllers are plugged in incorrectly (exchange the plugs between Vacuum Controller 1 and Vacuum Controller 2).
- ② In the Electrical Supply Unit the connecting wires for the Vacuum Valve are plugged incorrectly (exchange the plugs between Vacuum Valve 1 and Vacuum Valve 2).
- ▶ If the pump or the system does not operate properly and you cannot find any of the above faults, send them to the KNF Service Department.
- ▶ In order for KNF to repair the pump, the customer must provide a statement on the media which were pumped and on pump cleaning. Please fill out the corresponding KNF form, and submit it together with the pump. A sample statement for copying can be found in the Appendix of these operating instructions.

7. Changing the Pump Diaphragms and the Valve Plates/Sealings

Structured diaphragm and valve plates/sealings are the only parts subject to wear. It is easy to change them. In the case of two-headed pumps the structured diaphragms in both pump heads should be changed at the same time. When the structured diaphragms are changed, valve plates/sealings should also be replaced. If the structured diaphragms are not changed in both heads at the same time or the structured diaphragms and valve plates/sealings are not changed at the same time the nominal performance of the pump is not guaranteed after the service.

⚠ If a pump has been used for aggressive or toxic substances or other types of substances which are hazardous, hazardous to health, or injurious, the following points must be observed:

- 1.) Clean the pump and its components before servicing.
 - 2.) Ensure that the service personnel is not subject to a health hazard. Apply the safety and protection measures that are necessary for the medium that has been handled by the pump (example: the use of protective gloves).
 - 3.) Ensure that discarded parts and materials are safely and correctly disposed of.
- ▶ Use only original KNF replacement parts.

7.1 One-headed pumps:

Pump types
N 810 FT.18
N 820 FT.18
N 840 FT.18

Required tools and material:

- Service Set (see section 8.2);
- Philips-head screwdriver No. 2.

Change the structured diaphragms and valve plates/sealings in the following sequence:

- a.) Preparatory steps
- b.) Remove pump head
- c.) Change structured diaphragm
- d.) Change valve plates/sealings
- e.) Refit pump head
- f.) Final steps

- ▶ The position numbers in the fol-

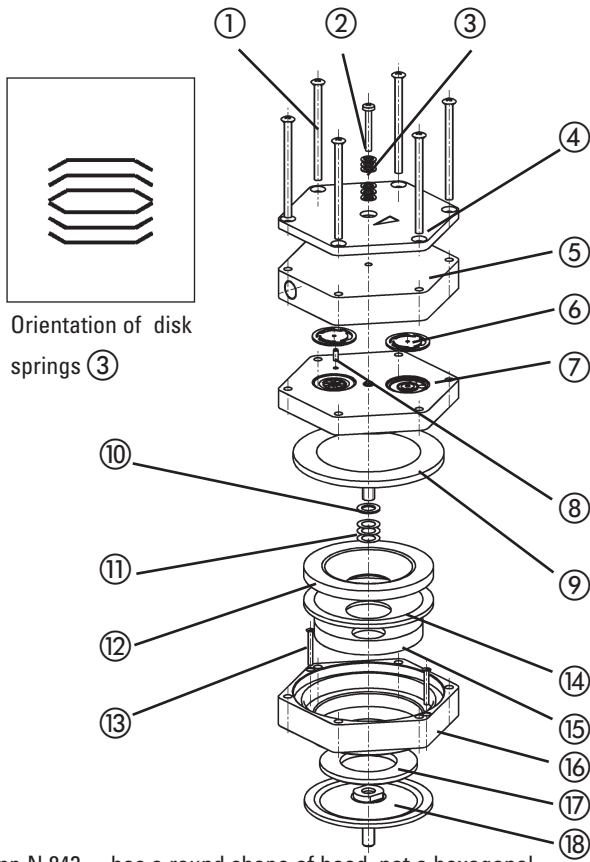

Pump N 842__ has a round shape of head, not a hexagonal

Specification

① Screw ⁽¹⁾	⑨ Structured diaphragm	⑱ Dampening diaphragm ⁽⁴⁾
② Screw ⁽²⁾	⑩ Spacer (thick)	(1) 6 x; N 842_: 12 x
③ Disk spring	⑪ Spacer (thin)	(2) 1 x; N 842_: 3 x
④ Top plate	⑫ Dampening ring A	(3) N 810_: 0 x
⑤ Head plate	⑬ Screw	N 820_: 2 x
⑥ Valve plate/sealing	⑭ Dampening felt ⁽³⁾	N 840_: 1 x
⑦ Intermediate plate	⑮ Dampening ring B ⁽⁴⁾	N 842_: 1 x
⑧ Guide pin	⑯ Adapter	(4) only for pump types
	⑰ Dampening ring C ⁽⁴⁾	N 840__ and N 842__

Fig. 17: Pump head (exploded drawing, symbolic)

lowing text refer to fig. 17.

a.) Preparatory Steps

- ① Shut down system (see section 5) including disconnecting the pump from the power source (pull out plug of electrical supply unit or of socket).
- ② Remove tubing from the inlet and outlet connectors of the pump.
- ③ If the pump is integrated in a vacuum system: Remove pump from the Baseplate.

b.) Removing the pump head

- ① Loosen the outer screws ① on the pump head.
- ② Carefully remove pump head (top plate ④, head plate ⑤ and intermediate plate ⑦).

c.) Change structured diaphragm

- ① Carefully unscrew the structured diaphragm ⑨ anti-clockwise using both hands.
- ② Replace all spacers ⑩/⑪ onto the screw thread of the new structured diaphragm (same number and order)
- ③ Screw in the new structured diaphragm ⑨ and tighten it by hand; you do not need any tool.

d.) Change valve plates/ sealing rings

- ① Unscrew the single screw ② in the top plate ④.
- ② Carefully remove top plate ④ and head plate ⑤ from intermediate plate ⑦; exposing the valve plates/sealings ⑥.

- ③ Remove old valve plate/sealings ⑥.
- ④ If there should be deposits in the recesses in the intermediate plate ⑦, clean them until the deposits have been completely removed.
- ⑤ Insert new valve plates/sealings ⑥ in the recesses in the intermediate plate ⑦ (upper and lower sides of the valve plates/sealings are identical).

e.) Refitting the pump head

- ① Press the lip on the edge of the structured diaphragm ⑨ into the groove in the housing.
- ② Place the intermediate plate ⑦, with the valve plates/sealings on the adapter ⑯, in the position indicated by the guide pin ⑧.
- ③ Place the head plate ⑤ on the intermediate plate ⑦ in the position indicated by the guide pin ⑧.
- ④ Place the top plate ④ on the head plate ⑤ in the right position.
- ⑤ Gently tighten screws ① in diagonal order.
- ⑥ Screw in the single screw ② in the centre of the pump top plate ④ until it is flush with the top plate (they are flush with the top plate); then screw one final half turn to tighten.
 - ▶ For orientation of disk springs ③ see fig. 17.

f.) Final steps

- ① Remount the pump to the baseplate.
 - ② Reconnect system tubing.
 - ③ Reconnect the pump to the electricity supply.
- ▶ **If the pump does not reach the desired vacuum after changing diaphragms and valve plates:**
- ① Check whether the spacers have been replaced onto the diaphragm screw thread.
 - ② Check the tubing for leaks.
 - ③ Possibly the screws ① on the pump head are insufficiently tightened (carefully tighten them again crosswise).
- ▶ If you have any questions about servicing call our technical adviser (see last page for contact telephone number).

7.2 Two-headed pumps:

Pump types

N 810.3 FT.18

N 820.3 FT.18

N 840.3 FT.18

N 840.1.2 FT.18

N 842.3 FT.18

Required tools and material:

- Service Set (see section 8.2);
- Philips-head screwdriver No. 2.

Change the structured diaphragms and valve plates/sealings in the following sequence:

- a.) Preparatory steps
- b.) Remove pump heads
- c.) Change structured diaphragms
- d.) Change valve plates/sealings
- e.) Refit pump heads
- f.) Final steps

► The position numbers in the following text refer to fig. 17.

a.) Preparatory Steps

- ① Shut down system (see section 5) including disconnecting the pump from the power source (pull out plug of electrical supply unit or of socket).
- ② Remove tubing from the inlet and outlet connectors of the pump.
- ③ If the pump is integrated in a vacuum system: Remove pump from the Baseplate.

b.) Removing the pump heads

- ① On the pneumatic head connections, loosen one of the union nuts by hand. Then slightly loosen the angle-fitting in the pump head by turning it **anticlockwise**, so that the connecting tube can be pulled out.
- ② Loosen the outer screws ① on each pump head.
- ③ Carefully remove both pump heads (top plate ④, head plate ⑤ and intermediate plate ⑦).

c.) Change structured diaphragms

- ① Push down one structured diaphragm ⑨ until other structured diaphragm is pushed upwards to its highest position.
- ② Carefully unscrew the higher structured diaphragm anti-clockwise using both hands.
- ③ Replace all spacers ⑩/⑪ onto the screw thread of the new structured

red diaphragm (same number and order)

- ④ Screw in the new structured diaphragm ⑨ and tighten it by hand; you do not need any tool.
 - ⑤ Change the second structured diaphragm as described above (step ① to ④) for the first.
- Changing the two structured diaphragms one after the other ensures that the same number of diaphragm spacers are refitted as were removed. This is essential to maintain the pneumatic performance of the pump.

d.) Change valve plates/sealings

- ① For one pump head: Unscrew the single screw ② (N 842.3 FT.18: three screws) in the top plate ④.
- ② Carefully remove top plate ④ and head plate ⑤ from intermediate plate ⑦; exposing the valve plates/sealings ⑥.
- ③ Remove old valve plate/sealings ⑥.
- ④ If there should be deposits in the recesses in the intermediate plate ⑦, clean them until the deposits have been completely removed.
- ⑤ Insert new valve plates/sealings ⑥ in the recesses in the intermediate plate ⑦ (upper and lower sides of the valve plates/sealings are identical).
- ⑥ Carry out the steps ① to ⑤ for the second pump head.

e.) Refitting the pump heads

- ① For one pump head: Press the lip on the edge of the structured diaphragm ⑨ into the groove in the housing.
- ② Place the intermediate plate ⑦, with the valve plates/sealings on the adapter ⑫, in the position indicated by the guide pin ⑧.
- ③ Place the head plate ⑤ on the intermediate plate ⑦ in the position indicated by the guide pin ⑧.
- ④ Place the top plate ④ on the head plate ⑤ in the right position.
- ⑤ Gently tighten screws ① in diagonal order.
- ⑥ Screw in the single screw ② (N 842.3 FT.18: three screws) in the centre of the pump top plate ④ until it is flush with the top plate (they are flush with the top plate);

then screw one final half turn to tighten.

- For orientation of disk springs ③ see fig. 17.
- ⑦ Carry out steps ① to ⑥ for the second pump head.
 - ⑧ Refit the pneumatic head connection: Place tube onto the connecting part of the angle fitting, turn angle fitting to a straight position and tighten the union nut.

f.) Final steps

- ① Remount the pump to the baseplate.
 - ② Reconnect system tubing.
 - ③ Reconnect the pump to the electricity supply.
- **If the pump does not reach the desired vacuum after changing diaphragms and valve plates/sealings:**
- ① Check whether the spacers have been replaced onto the structured diaphragm screw thread.
 - ② Check the interconnecting pipe-work connection between both pump heads as well as the tubing for leaks.
 - ③ Possibly the screws on one of the pump heads (or both heads) are insufficiently tightened (carefully tighten them again crosswise).
- If you have any questions about servicing call our technical adviser (see last page for contact telephone number).

8 Ordering Information

8.1 LABOPORT®-Vacuum Pumps

Model:	Order No.
N 810 FT.18	057986
N 820 FT.18	057901
N 840 FT.18	057911
N 810.3 FT.18	057500
N 820.3 FT.18	057501
N 840.3 FT.18	057502
N 840.1.2 FT.18	057571
N 842.3 FT.18	057634

8.2 Replacement Parts Service Set

A Service Set contains all replacement parts needed for one complete service.

- One-headed pumps:
Service Set contains
1 diaphragm, 2 valve plates/sea-
lings.

For pump type: Order No.
N 810 FT.18 058077
N 820 FT.18 058078
N 840 FT.18 058079
- Two-headed pumps:
Service Set contains
2 diaphragms, 4 valve plates/sea-
lings.

For pump type: Order No.
N 810.3 FT.18 057357
N 820.3 FT.18 057358
N 840.3 FT.18 057359
N 840.1.2 FT.18 057359
N 842.3 FT.18 057359

8.3 Accessories for the modular LABOPORT®-System

- **Baseplate and mounting for pumps**
N 810 FT.18
N 810.3 FT.18
N 820 FT.18
N 820.3 FT.18
Item: **NP 810/820** Order No. **28129**
- **Baseplate and mounting for pumps**
N 840 FT.18
N 840.1.2 FT.18
N 840.3 FT.18
N 842.3 FT.18
Item: **NP 840** Order No. **28128**
- **Separator complete including tray**
Item: **NR 800** Order No.: **26225**

- **High Performance Condenser complete including Support**
Item: **NH 800** Order No. **26231**
- **Gas Ballast for pump**
N 810.3FT.18
Item: **NG 810** Order No. **28476**
- **Gas Ballast for pumps**
N 820.3FT.18
N 840.3FT.18
N 842.3 FT.18
Item: **NG 820/840** Order No. **28477**
- **Vacuum-Controller NC 800 complete including Support and Electrical Supply Unit**
Item: **NC 800A** Order No. **46380**
- **Vacuum-Controller NC 800 complete without Electrical Supply Unit** (for Upgrading from SC... to SCC...)
Item: **NC 800B** Order No. **46381**
- **Two Vacuum Controllers NC 800 complete including Support and Electrical Supply Unit**
Item: **NC 800A/B** Order No. **46382**
- **Vacuum chemical tubing**
for pneumatic connections of
LABOPORT® systems;
material: Norprene A 60 G;
unit of length: 1 meter

Order No.: **028187**

Please specify the required length (in whole meters); for required length see section 3. *Assembling or Upgrading your System.*

9 Specifications

9.1 Pump

N 810 FT.18

Maximum capacity:	10 l/min
Ultimate vacuum:	≤ 100 mbar abs
Maximum continuous pressure:	1 barg (14.7 psi)
Weight of pump:	5.9 kg
Permissible ambient temperature:	+ 5... + 40 °C
Permissible temperature of gas to be pumped:	+ 5... + 40 °C

Electrical Type

Voltage [V]	100	115	230
Frequency [Hz]	50/60	60	50

Power Consumption Pump [W]	100	110	90
----------------------------	-----	-----	----

Fuse Pump (2x) T [A]	2.5	2.5	1.25
----------------------	-----	-----	------

N 820 FT.18

Maximum capacity:	20 l/min
Ultimate vacuum:	≤ 100 mbar abs
Maximum continuous pressure:	1 barg (14.7 psi)
Weight of pump:	7.1 kg
Permissible ambient temperature:	+ 5... + 40 °C
Permissible temperature of gas to be pumped:	+ 5... + 40 °C

Electrical Type

Voltage [V]	100	115	230
Frequency [Hz]	50/60	60	50

Power Consumption Pump [W]	145	145	130
----------------------------	-----	-----	-----

Fuse Pump (2x) T [A]	4.0	3.5	2.0
----------------------	-----	-----	-----

N 840 FT.18

Maximum capacity:	34 l/min
Ultimate vacuum:	≤ 100 mbar abs
Maximum continuous pressure:	1 barg (14.7 psi)
Weight of pump:	10.3 kg
Permissible ambient temperature:	+ 5... + 40 °C
Permissible temperature of gas to be pumped:	+ 5... + 40 °C

Electrical Type

Voltage [V]	100	115	230
Frequency [Hz]	50/60	60	50

Power Consumption Pump [W]	200	220	180
----------------------------	-----	-----	-----

Fuse Pump (je 2) T [A]	6.3	6.3	3.15
------------------------	-----	-----	------

N 810.3 FT.18

Maximum capacity:	10 l/min
Ultimate vacuum:	≤ 8 mbar abs
Maximum continuous pressure:	1 barg (14.7 psi)
Weight of pump:	6.9 kg
Permissible ambient temperature:	+ 5... + 40 °C
Permissible temperature of gas to be pumped:	+ 5... + 40 °C

Electrical Type

Voltage [V]	100	115	230
Frequency [Hz]	50/60	60	50

Power Consumption Pump [W]	100	110	90
----------------------------	-----	-----	----

Fuse Pump (2x) T [A]	2.5	2.5	1.25
----------------------	-----	-----	------

N 820.3 FT 18

Maximum capacity:	20 l/min
Ultimate vacuum:	≤ 8 mbar abs
Maximum continuous pressure:	1 barg (14.7 psi)
Weight of pump:	9.3 kg
Permissible ambient temperature:	+5... +40°C
Permissible temperature of gas to be pumped:	+5... +40°C

Electrical Type

Voltage [V]	100	115	230
Frequency [Hz]	50/60	60	50

Power Consumption Pump [W]	130	130	120
----------------------------	-----	-----	-----

Fuse Pump (2x) T [A]	3.15	2.5	1.6
----------------------	------	-----	-----

N 840.3 FT.18

Maximum capacity:	34 l/min
Ultimate vacuum:	≤ 8 mbar abs
Maximum continuous pressure:	1 barg (14.7 psi)
Weight of pump:	12.6 kg
Permissible ambient temperature:	+5... +40°C
Permissible temperature of gas to be pumped:	+5... +40°C

Electrical Type

Voltage [V]	100	115	230
Frequency [Hz]	50/60	60	50

Power Consumption Pump [W]	220	250	245
----------------------------	-----	-----	-----

Fuse Pump (2x) T [A]	6.3	6.3	3.15
----------------------	-----	-----	------

N 840.1.2 FT.18

Maximum capacity:	60 l/min
Ultimate vacuum:	≤ 90 mbar abs
Maximum continuous pressure:	1 barg (14.7 psi)
Weight of pump:	12.6 kg
Permissible ambient temperature:	+ 5... + 40 °C
Permissible temperature of gas to be pumped:	+5... +40°C

Electrical Type

Voltage [V]	100	115	230
Frequency [Hz]	50/60	60	50
Power Consumption Pump [W]	275	280	270
Fuse Pump (2x) T [A]	6.3	6.3	4.0

N 842.3 FT.18

Maximum capacity:	34 l/min
Ultimate vacuum:	≤ 2 mbar abs
Maximum continuous pressure:	1 barg (14.7 psi)
Weight of pump:	13.4 kg
Permissible ambient temperature:	+ 5... + 40 °C
Permissible temperature of gas to be pumped:	+ 5... + 40 °C

Electrical Type

Voltage [V]	100	115	230
Frequency [Hz]	50/60	60	50
Power Consumption Pump [W]	260	290	245
Fuse Pump (2x) T [A]	6.3	6.3	3.15

9.2 Electrical Supply Unit

Voltage [V]	100	115	230
Frequency [Hz]	50/60	60	50
Power Consumption* [W]	280	280	250
Fuse (2x) T [A]	6.3	6.3	3.15

*. includes the Power Consumption of the whole system (inclusive pump and Vacuum Controller); for pumps N 840.1.2 FT.18 and N 842.3 FT.18 power consumption raises by 50 W.

9.3. Vacuum Controller

See Operating Manual of the Vacuum Controller.

► CE - Safety Demands

- The KNF LABOPORT® pumps correspond to the safety regulations of the EU low voltage directive 73/23 EWG and of the EU directive concerning electromagnetic compatibility 89/336 EWG. The requirements of the following harmonised standards are fulfilled: EN 61010 Part 1, EN 50081 Part 1, EN 50082 Part 1.
- The pumps correspond to IEC 664:
 - the overvoltage category II
 - the pollution degree 2.

KNF Neuberger GmbH
Alter Weg 3
D-79112 Freiburg

Phone ++ 49 / 76 64 / 59 09-0
Fax ++ 49 / 76 64 / 5909-99
www.knf.de
E-mail: info@knf.de

**Appendix:
Customer statement for
repair order (sample
statement for copying)**

- ▶ In order for KNF to repair the pump, the customer must provide a statement on the media which were pumped and on pump cleaning. Please fill out the corresponding KNF form, and submit it together with the pump.

Statement/Certificate

We confirm that the pump model listed below (please specify)

.....
.....

Serial-No. (please specify)

.....
.....

was used to pump the following media:

.....
.....
.....
.....
.....
.....

and that the pump listed above was cleaned. There are no poisonous, aggressive, biological, radioactive or other dangerous media in the pump.

.....
Company

.....
Date/
Signature

**KNF Neuberger GmbH
Alter Weg 3
D-79112 Freiburg**

**Phone ++ 49 / 76 64 / 59 09-0
Fax ++ 49 / 76 64 / 5909-99
www.knf.de
E-mail: info@knf.de**

