

## DIAPHRAGM VACUUM PUMPS FOR THE STERILIZATION AND DRYING

## DATA SHEET E 180



**N 836 APE**, basic model



**N 836.3 AP .40 E**, with magnetic valve



**N 836.3 AP .41 E**, with magnetic valve and air-cooled heads

### Concept

The one and two-headed Diaphragm Vacuum Pumps from KNF are based on a simple principal - an elastic diaphragm, fixed on its edge, moves up and down its central point by means of an eccentric. In this way the medium is transferred using automatic valves.

The pumps are equipped with the patented stress-optimised structured diaphragm, resulting in a high pneumatic performance, a durable product and compact size. Special valves ensure that the product can cope easily with vapour and condensation.

Thanks to the KNF modular system, the parts used to transfer the gases can be made from materials with varying degrees of durability. Various AC motors are available for pump drive.

### Features

#### Uncontaminated flow

No pollution of the media

#### Maintenance-free

#### Patented pump system for autoclaves

#### Various technical options:

- The low-cost model
- The model with integrated Magnetic valve for automatic rinsing
- As above, however with additional cooling of the pump heads for vapour condensation
- Connection for water cooling, please contact us for more details.

#### Very high vapour and condensation compatibility

#### High level of gas tightness

#### Long product life

#### Negligible current loss

### Areas of use

The diaphragm vacuum pumps, with their high level of performance despite their compact size, combined with patented technology and an excellent price to performance ratio, are used especially in autoclave systems (vacuum sterilisation) and dry cabinets (vacuum drying).

The pumps suck out air, gases and vapours and in so doing evacuate for example containers or chambers of autoclave system.

## PERFORMANCE DATA

TypE	Delivery (l/min)	Vacuum (mbar absolute)	atm. Press.	Pressure (bar g)	Weight (kg)
N 836 APE	31	80		0.5	4.85
N 836 AP .40 E	31	80		0.5	4.95
N 836 AP .41 E	31	80		0.5	5.45
N 836.3 APE	31	10		0.5	7.1
N 836.3 AP .40 E	31	10		0.5	7.2
N 836.3 AP .41 E	31	10		0.5	8.3

# N 836 APE

# N 836 AP .40 E

## Model with automatic rinsing

### PERFORMANCE DATA

Type and Order No. <sup>3)</sup>	Delivery at atm. pressure (l/min) <sup>1)</sup>	Max. operating pressure (bar g)	Ultimate vakuu (mbar abs.)
<b>N 836 APE</b>	31	0.5	80

<sup>1)</sup> Litre at STP

### PERFORMANCE DATA

Type and Order No. <sup>3)</sup>	Delivery at atm. pressure (l/min) <sup>1)</sup>	Max. operating pressure (bar g)	Ultimate vakuu (mbar abs.)
<b>N 836 AP .40 E</b>	31	0.5	80

<sup>1)</sup> Litre at STP

### MOTOR DATA

Protection class	IP 00		
Voltage/Frequencies (V/Hz)	230/50		
Power P <sub>1</sub> (W)	80		
Operating current (A)	0.45		

### MOTOR DATA

Protection class	IP 00		
Voltage/Frequencies (V/Hz)	230/50		
Power P <sub>1</sub> (W)	80		
Operating current (A)	0.45		

### MODEL CODES AND MATERIALS

Type and Order No. <sup>3)</sup>	Pump head <sup>5)</sup>	Diaphragm	Valves
<b>N 836 APE</b>	Aluminium/Ryton <sup>4)</sup>	EPDM	EPDM

<sup>5)</sup> Oxidised on the outside and coated on the inside

<sup>4)</sup> Phillips Petroleum registered trade mark

<sup>3)</sup> See also „MODEL CODES FOR EASY ORDERING“

### MODEL CODES AND MATERIALS

Type and Order No. <sup>3)</sup>	Pump head <sup>5)</sup>	Diaphragm	Valves
<b>N 836 APE</b>	Aluminium/Ryton <sup>4)</sup>	EPDM	EPDM

### Dimensions <sup>6)</sup> (mm)

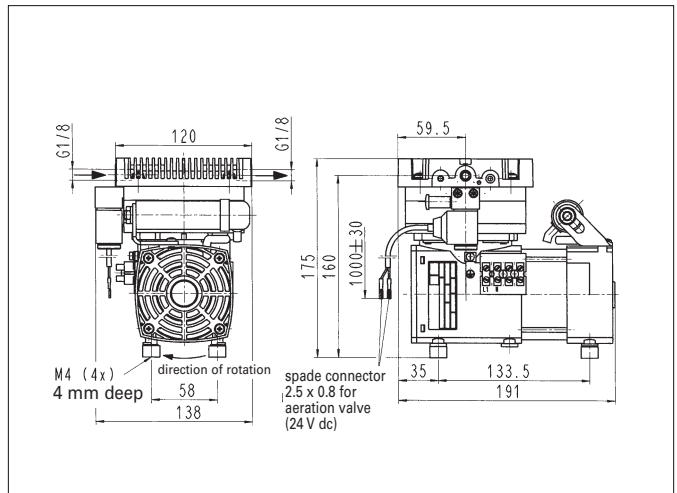
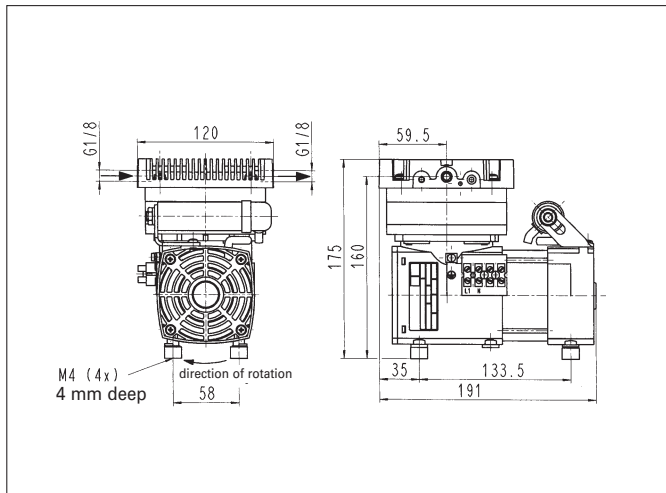

<sup>6)</sup> All dimensional tolerances conform to DIN ISO 2768-1, Tolerance Class V

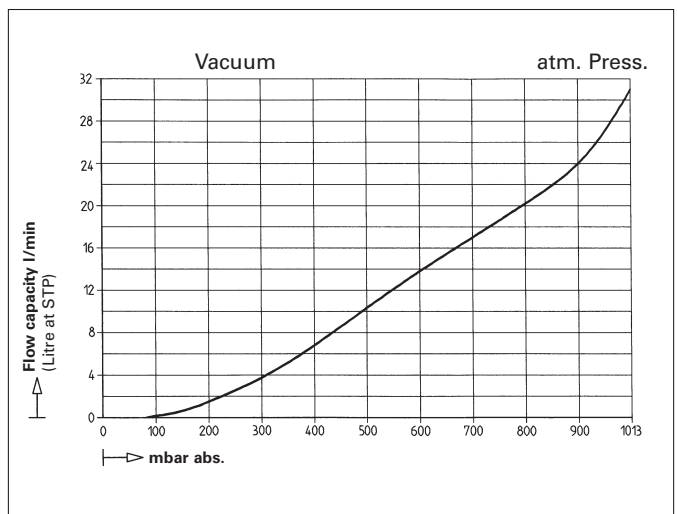
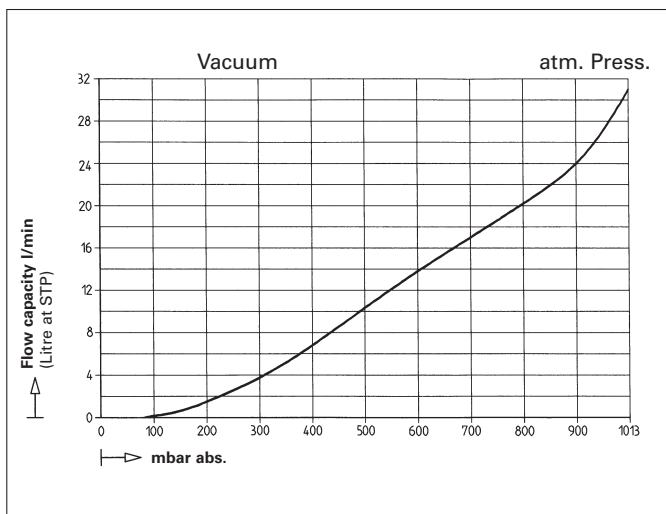

# N 836 AP .41 E

# N 836.3 APE

Model with automatic rinsing and air cooling (water cooling on request)

## PERFORMANCE DATA

Type and Order No. <sup>3)</sup>	Delivery at atm. pressure (l/min) <sup>1)</sup>	Max. operating pressure (bar g)	Ultimate vakuu (mbar abs.)
N 836 AP .41 E	31	0.5	80

<sup>1)</sup> Litre at STP

## MOTOR DATA

Protection class	IP 00		
Voltage/Frequencies (V/Hz)	230/50		
Power P <sub>1</sub> (W)	80		
Operating current (A)	0.45		

## MODEL CODES AND MATERIALS

Type and Order No. <sup>3)</sup>	Pump head <sup>5)</sup>	Diaphragm	Valves
N 836 APE	Aluminium/Ryton <sup>4)</sup>	EPDM	EPDM

## PERFORMANCE DATA

Type and Order No. <sup>3)</sup>	Delivery at atm. pressure (l/min) <sup>1)</sup>	Max. operating pressure (bar g)	Ultimate vakuu (mbar abs.)
N 836.3 APE	31	0.5	10

<sup>1)</sup> Litre at STP

## MOTOR DATA

Protection class	IP 00		
Voltage/Frequencies (V/Hz)	230/50		
Power P <sub>1</sub> (W)	100		
Operating current (A)	0.6		

## MODEL CODES AND MATERIALS

Type and Order No. <sup>3)</sup>	Pump head <sup>5)</sup>	Diaphragm	Valves
N 836 APE	Aluminium/Ryton <sup>4)</sup>	EPDM	EPDM

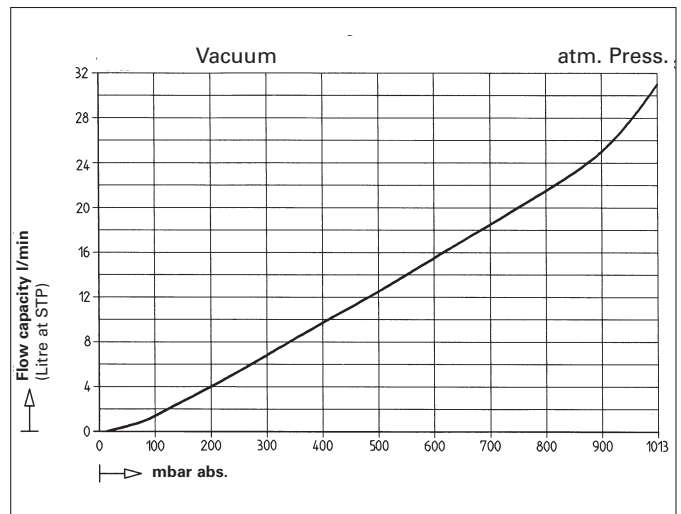
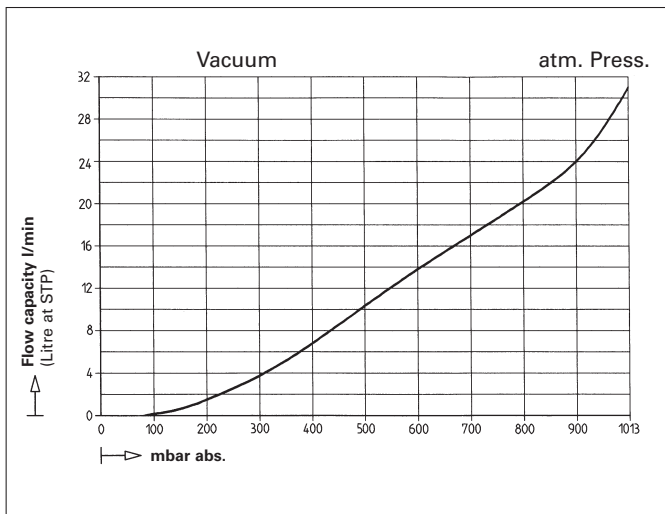
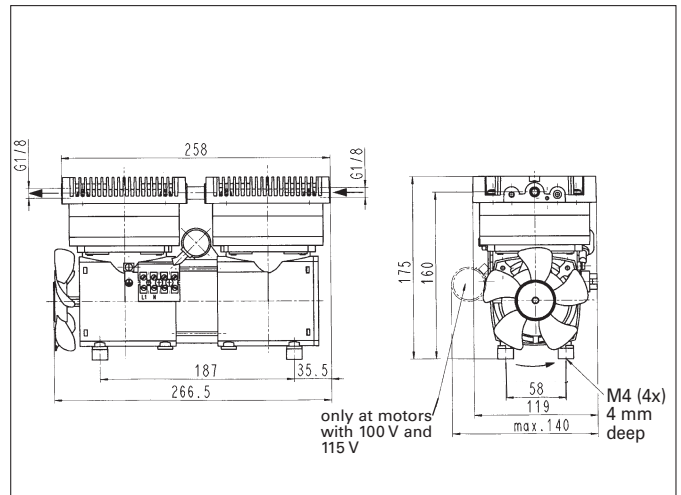
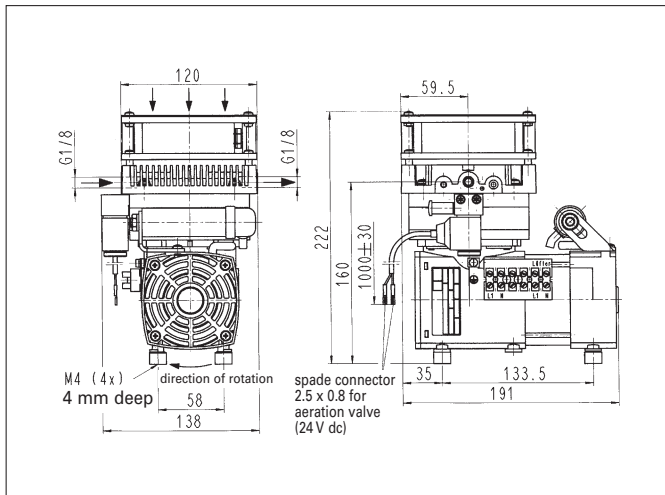

# N 836.3 AP .40 E

Model with automatic rinsing

## PERFORMANACE DATA

Type and Order No. <sup>3)</sup>	Delivery at atm. pressure (l/min) <sup>1)</sup>	Max. operating pressure (bar g)	Ultimate vakuüm (mbar abs.)
N 836.3 AP .40 E	31	0.5	10

<sup>1)</sup> Litre at STP

## MOTOR DATA

Protection class	IP 00		
Voltage/Frequencies (V/Hz)	230/50		
Power P <sub>1</sub> (W)	100		
Operating current (A)	0.6		

## MODEL CODES AND MATERIALS

Type and Order No. <sup>3)</sup>	Pump head <sup>5)</sup>	Diaphragm	Valves
N 836 APE	Aluminium/Ryton <sup>4)</sup>	EPDM	EPDM

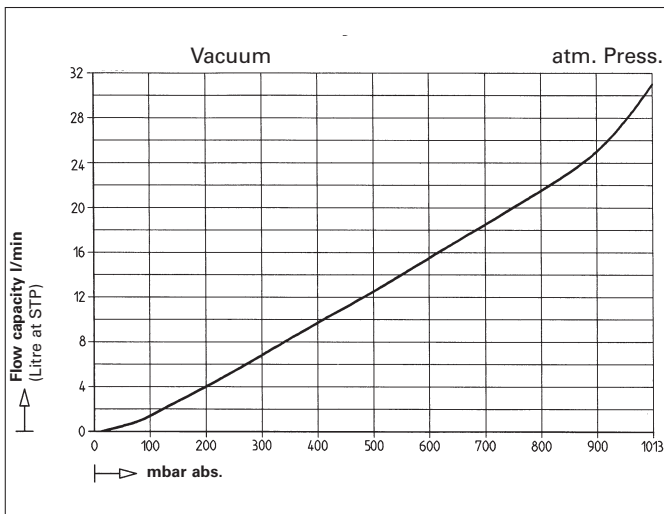
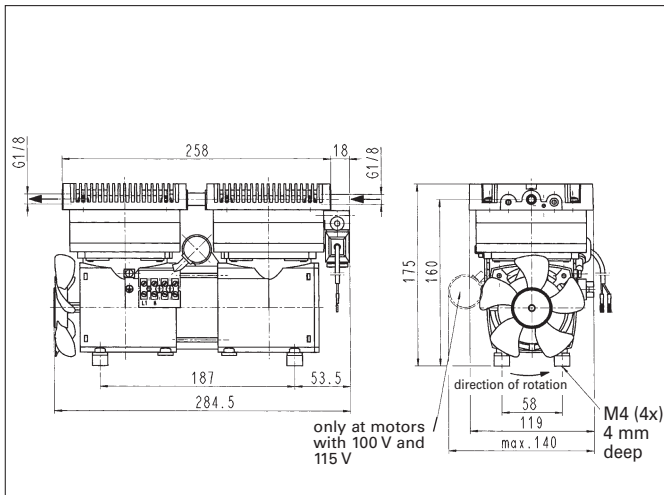

# N 836.3 AP .41 E

Model with automatic rinsing and air cooling (water cooling on request)

## PERFORMANACE DATA

Type and Order No. <sup>3)</sup>	Delivery at atm. pressure (l/min) <sup>1)</sup>	Max. operating pressure (bar g)	Ultimate vakuüm (mbar abs.)
N 836.3 AP .41 E	31	0.5	10

<sup>1)</sup> Litre at STP

## MOTOR DATA

Protection class	IP 00		
Voltage/Frequencies (V/Hz)	230/50		
Power P <sub>1</sub> (W)	810		
Operating current (A)	0.6		

## MODEL CODES AND MATERIALS

Type and Order No. <sup>3)</sup>	Pump head <sup>5)</sup>	Diaphragm	Valves
N 836 APE	Aluminium/Ryton <sup>4)</sup>	EPDM	EPDM

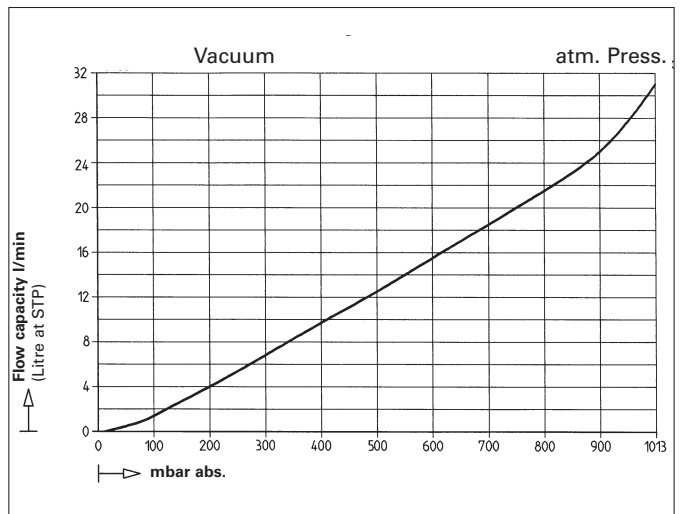
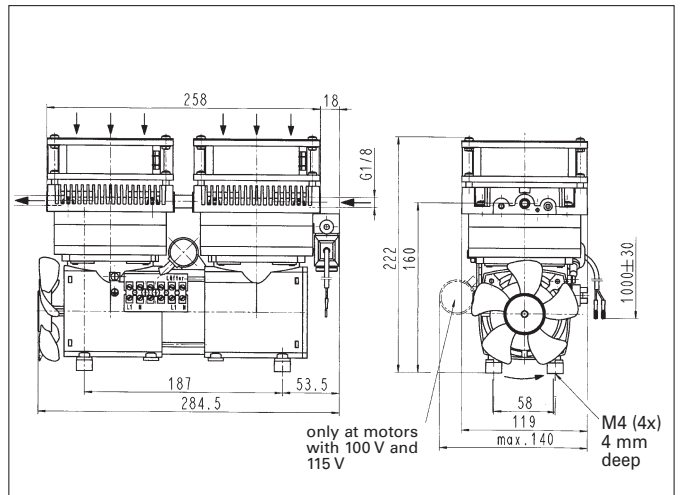

## Pump down time for 10 l receiver

**N 836 APE**

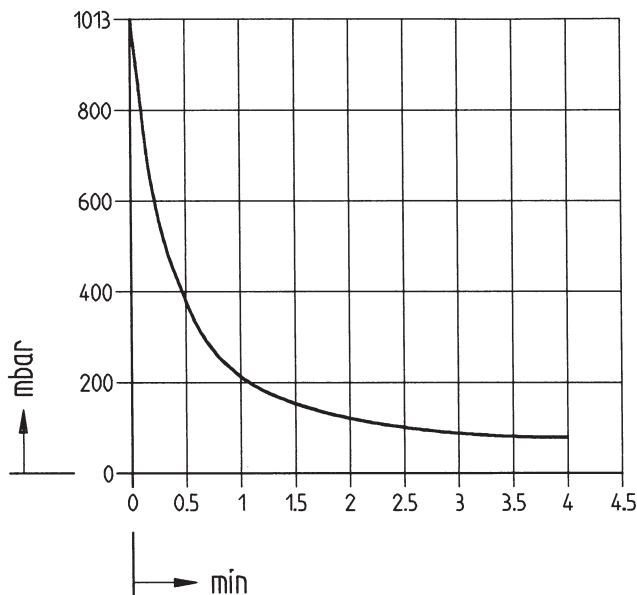

## MODEL CODE FOR EASY ORDERING

The model code is identical to the order number. It is made up as follows:

<b>N 836</b>	<b>.3</b>	<b>AP</b>	<b>.41</b>	<b>E</b>	<b>230 V/50 Hz, IP 00</b>
--------------	-----------	-----------	------------	----------	-------------------------------

- Base model
- Head connections
- Head materials
- Technical options, e.g.:  
Pump head with air cooling
- Version with ac motor
- Other motor data e.g.:

In addition the motor data must be given in the purchase order (voltage, frequency, and protection class). In our extensive program you are sure to find the pump you need for your particular application.

## TECHNICAL DETAILS

Maximum permissible gas and ambient temperature: between +5 °C and +40 °C.

Versions for higher gas temperature and with motors for other voltages, frequencies and protection classes on request.

Hints on function, installation, and service: see back page.

## Pump down time for 10 l receiver

**N 836.3 APE**

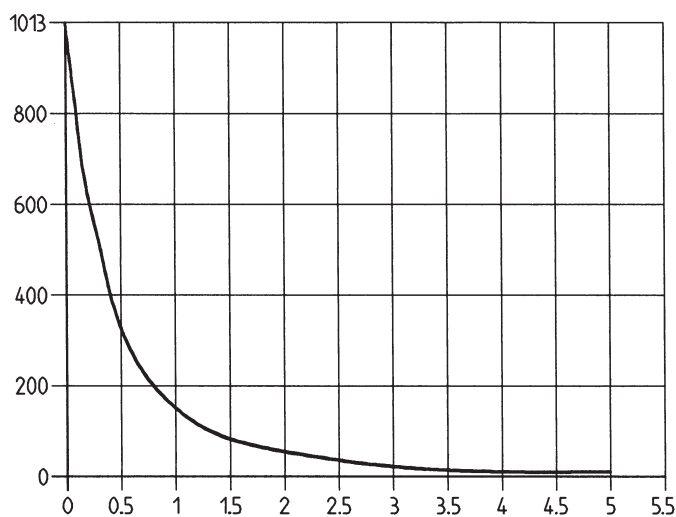

KNF - the competent partner for vacuum and compressor technology. Especially for unusual problems. Call us and talk to our application engineers.

## KNF Neuberger GmbH Diaphragm Pumps + Systems

Alter Weg 3  
D-79112 Freiburg  
Tel. ++49 (0)7664/5909-0  
Fax ++49 (0)7664/5909-99  
E-mail: info@knf.de  
www.knf.de

## HINTS ON FUNCTION, INSTALLATION AND SERVICE

### FUNCTION OF KNF DIAPHRAGM VACUUM PUMPS AND COMPRESSORS

An elastic diaphragm is moved up and down by an eccentric (see illustration). On the down-stroke it draws the air or gas being handled through the inlet valve. On the up-stroke the diaphragm forces the medium through the exhaust valve and out of the head. The compression chamber is hermetically separated from the drive mechanism by the diaphragm. The pumps transfer, evacuate and compress completely oil-free.

#### Diaphragm pump

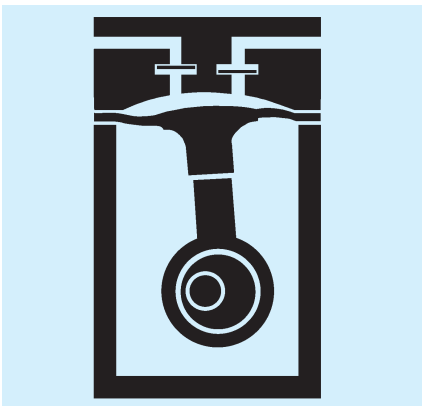

### HINTS ON INSTALLATION AND OPERATION

- Range of use: Transferring air, gases and vapours at temperatures between +5 °C and +40 °C. Versions for higher temperature on request
- Permissible ambient temperature: between +5 °C and +40 °C.
- The standard pumps are not suitable for use in areas where there is a risk of explosion. In these cases there are other products in the KNF program - please ask us for details.
- The pumps are not designed to start against pressure or vacuum; when a pump is switched on the pressure in the suction and pressure lines must be atmospheric. Pumps that start against pressure or vacuum are available on request.
- To prevent the maximum operating pressure being exceeded, restriction or regulation of the air flow should only be carried out in the suction line.

- Components connected to the pump must be designed to withstand the pneumatic performance of the pump.
- Install the pump so that the fan can draw in sufficient cooling air.
- Fit the pump at the highest point in the system, so that condensate cannot collect in the head of the pump - that prolongs working-life.

### HINTS ON SERVICE

The diaphragm and valve plates are the only parts of the KNF diaphragm pumps subject to wear. They are easy to change, as no special tools are needed.

If you have any questions, please call our application engineers (see below for contact telephone number).