

Modular Vacuum Systems, controlled Vacuum

INNOVATIVE
TECHNOLOGY
WORLDWIDE

KNF
NEUBERGER



Chemically-resistant LABOPORT® Vacuum Systems with Condenser, Separator and two Vacuum Controllers

Technical features:

- Maintenance-free
- Silent
- Simple connection to the line power (power plug) and to the pneumatic system
- Environmentally friendly
- Automatic vacuum control for two processes
- Controlled recovery of solvents, with high-performance condenser (at the pressure side)
- Collection of particles in the system (at the suction side)
- Easy to expand or convert

SCC Systems, modular

The SCC vacuum systems are equipped with the LABO-PORT-series chemically-resistant diaphragm pump of your choice (refer to the table/overview "modular accessories"). Fully-featured SCC systems have two vacuum controllers for two independent processes with just one pump. There is a wide range of applications for these vacuum systems in laboratories, whenever clean, constant vacuum is required.

The heart of the very compact LABOPORT pumps used in the vacuum systems is KNF structured diaphragm. This patented diaphragm was stress-optimized using the finite elements method. As a result, we were able to make the pumps smaller while increasing the service life of the diaphragm.

For laboratory applications, there is a wide variety of vacuum pumps with many different performance levels and various modular system components. The systems listed here are fully assembled at the factory. They can be converted quickly and easily; special tools are not required.

Complete SCC vacuum systems (fully-featured) with: chemically-resistant diaphragm pump of your choice, base plate, separator (suction side), condenser (pressure side), two vacuum controllers with electrical supply unit for controlling two independent processes, cabling and tubing ready to connect.

System ³⁾	Delivery (l/min) ¹⁾	Ultimate vacuum (mbar abs)	Operating pressure (bar g)	Motor ~230V/50Hz operating current (A)/ power P ₁ (W) ²⁾	Pneumatic connections for tube ID	Weight (kg)	Dimensions (LxHxW) (mm)	Built in pump type
SCC system comprising vacuum pump, base plate, condenser, separator, and two vacuum controllers								
SCC 810	10	8	1	0.6/90	10 mm	15.2	397/289/506	N 810.3 FT.18
SCC 820	20	8	1	0.7/120	10 mm	17.6	397/289/506	N 820.3 FT.18
SCC 840	34	8	1	1.8/245	10 mm	20.9	417/289/506	N 840.3 FT.18
SCC 842	34	2	1	1.8/245	10 mm	21.7	417/289/506	N 842.3 FT.18

¹⁾ at atm. pressure ²⁾ Motors with other voltages, frequencies on request

³⁾ systems with single head pumps and lower vacuum on request

Modular Vacuum Systems, controlled Vacuum

INNOVATIVE
TECHNOLOGY
WORLDWIDE

KNF
NEUBERGER



Dimensions (see table)

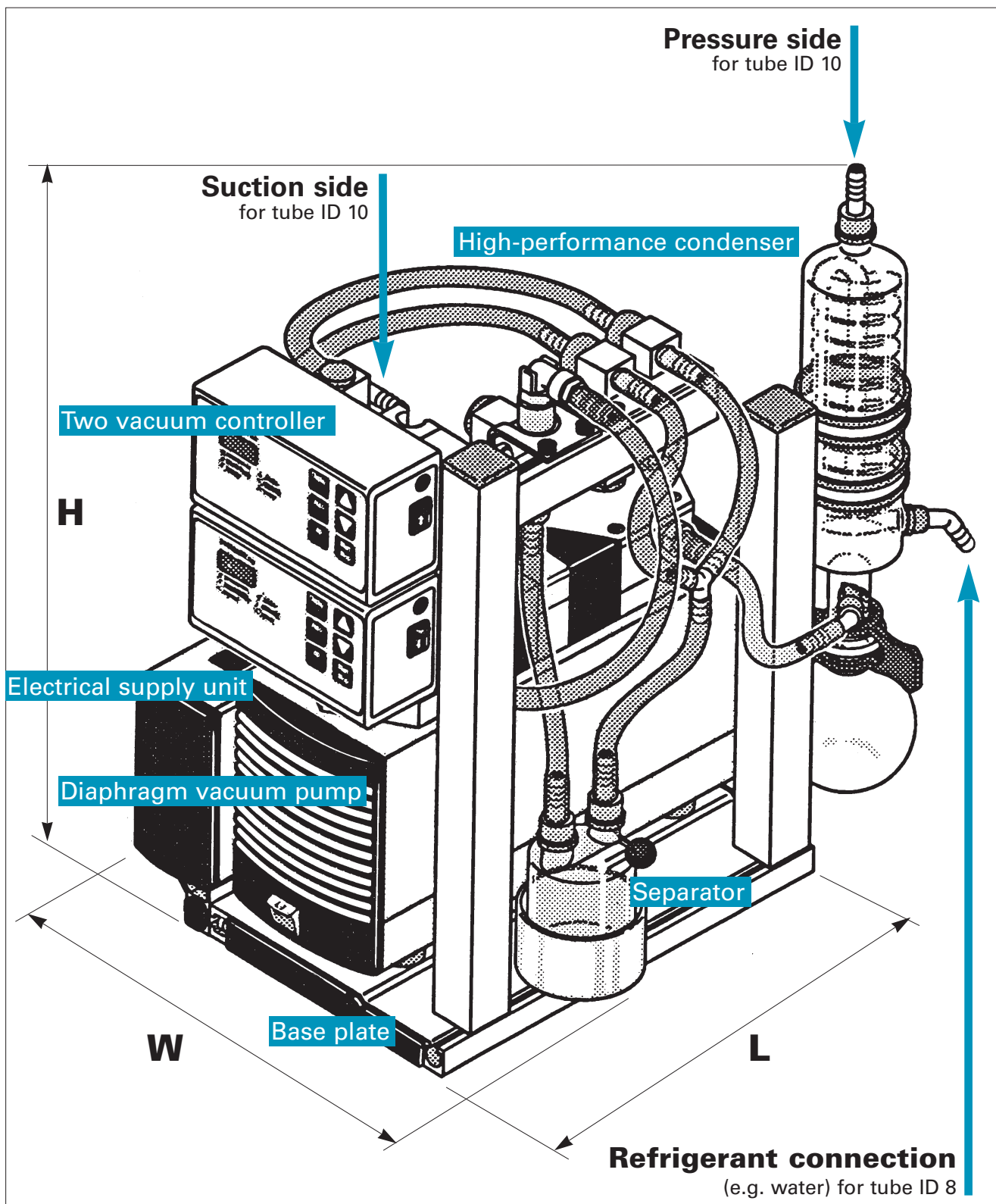

Accessories

Order No.	Description	Details
045075	Cooling water valve	G 1/2, ID 8

KNF Neuberger GmbH, Alter Weg 3, D-79112 Freiburg, Tel. ++49(0)7664/5909-0, Fax ++49(0)7664/5909-99, www.knf.de, E-Mail: info@knf.de

KNF reserves the right to make changes.

KNF 3/2004 Produced in Germany