

DIAPHRAGM LIQUID PUMPS NF 100 / 1.100

DATA SHEET E 515



NF 100 KPDCB



NF 1.100 KPE



NF 100 KP.27AA



Concept

KNF diaphragm liquid pumps are based on the principle of the oscillating displacement pump which is remarkably simple in design. The circular power from the motor is converted into vertical movement by an eccentric. This motion is then transferred to a diaphragm by means of a connecting rod which in conjunction with an inlet and outlet valve creates a pumping action.

NF 100/1.100 type liquid pumps can be mounted in any position and can deliver up to 1.3 l/min. depending on the model and will operate against pressures of up to 60 mWg.

The KNF modular system contains a wide standard range of materials, motors, voltages and frequencies to enable the selection of an optimal solution for your application.

Features

Self-priming and excellent for pressure

Sophisticated diaphragm technology and precise valve structures enable performances, depending on model, of up to 4 mWg suction and 60 mWg pressure.

Extreme chemical resistance

The use of chemically resistant materials such as PTFE, PVDF, FFPM or other material combinations for the parts which come in contact with the liquid allows almost all neutral or corrosive liquids to be pumped.

Dry running, durable and maintenance free

The carefully considered design of these pumps allows them to be run dry and ensures safe operation and a long life even under the most severe conditions.

Areas of use

The versatility of KNF pumps allows a wide field of applications to be covered. Over many years our pumps have proved themselves in the following areas:

Analysers

- Medical / pharmaceutical
- Environmental / water treatment
- Food / toxicology

Laboratory

- Filtration
- Chromatography

Cleaning industry

- Cuvette cleaning
- Sterilisers
- Industrial washing machines

Printing

- Ink jet printing
- Photographic / film development

Other applications for diaphragm liquid pumps include: fuel cells, hydrogen generators, CD coating, dental technology, textiles and many more.

Performance Data

Type	Flow rate (l/min.)	Suction head (mWg)	Pressure head (mWg)
NF 100	1.2	4	10
NF 1.100	1.3	4	60

Basic models



General note

This Data Sheet provides an overview of the options with our NF 100/1.100 pumps. Certain standard options will be explained in more detail where necessary.

Flow curves

The flow curves illustrate how the flow rate alters in relation to the pressures before and after the pump. In the case of a combination of both we would be very happy to advise what the expected flow rate would be.

The values given in the curves are dependant upon the liquid, choice of head materials and the type of hoses being used. Therefore a certain deviation is to be expected.

Note: The flow rate is measured with water at 20°C.

Basic models

NF 100	Liquid diaphragm pump for pressures of up to 10 mWg (1 barg)
NF 1.100	Liquid diaphragm pump for pressures of up to 60 mWg (6 barg)

1 Materials of head components

KNF FLODOS offers a wide range of different materials for those parts which come in contact with the liquid thus allowing the possibility of pumping most liquids.

2 Head types

- Standard

The pump head of the NF 100/1.100 is made up of eight main parts. The diaphragm, intermediate plate, connection plate, O-Ring, resonating diaphragm and the valves are the only parts which come in contact with the liquid. The materials which are available as standard can be seen in the table.

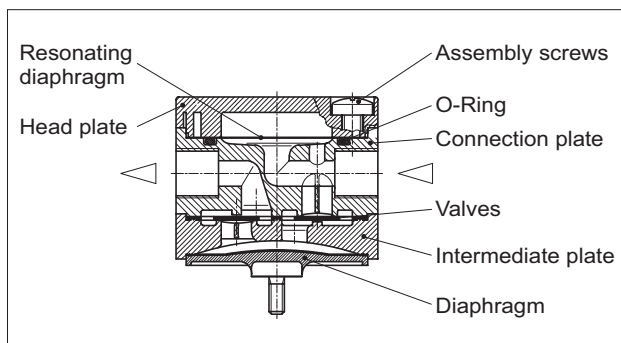

.27 Integrated overpressure relief valve

The integrated overpressure relief valve is available for all NF 100/1.100 pumps.

How it works

If the pump runs against a closed system the pressure will increase rapidly thus exceeding the allowed limits. In order to prevent this from happening a relief valve has been integrated into the head. Should the pressure exceed the adjusted value (min. 0.5 barg), the valve will open allowing the liquid to pass through the built-in bypass from the outlet to the inlet side.

Note: The valve is adjusted in the factory to a standard value of 1.5 barg (NF 100) and 6.5 barg (NF 1.100).

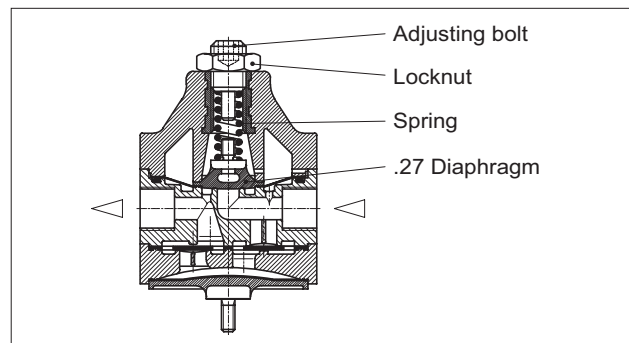

Areas of use

The valve can be used to prevent damage from occurring to the pump itself, hoses, valves and the system as a whole due to excessive pressures which can build up because of blockages or faulty valves.

3 Motors

- E Shaded pole motor (AC)
- AA Capacitor motor (AC)
- DC Direct current motor
- DCB Brushless direct current motor
This type of motor has no brushes which can wear down thus giving it a lifetime comparable with an AC motor.
Option: control possibility via PWM or 0-5V DC signal

4 Voltages / Frequencies

Choose from the different electrical connection possibilities. Special variations are available.

The KNF Modular Concept of Selection



Our versatile self-selection program allows you to personally determine the optimum characteristics that you require from your pump. Select your diaphragm pump from the following characteristics:

Flow rate at atmos. pressure (l/min.)	Max. suction head (mWg)	Max. pressure head (mWg)	Pump type				
			Basic model	Components			
				1	2	3	4
1.2	4	10	NF 100				
1.3	4	60	NF 1.100				

1	Materials of head components	
KP	Head	PP
	Valves	EPDM
	Diaphragm	PTFE
	Resonating diaphragm	PTFE
	O-Ring	EPDM
	.27 Diaphragm	EPDM
KT	Head	PP
	Valves	FFPM
	Diaphragm	PTFE
	Resonating diaphragm	PTFE
	O-Ring	PTFE
	.27 Diaphragm	FFPM
TT	Head	PVDF
	Valves	FFPM
	Diaphragm	PTFE
	Resonating diaphragm	PTFE
	O-Ring	PTFE
	.27 Diaphragm	FFPM

2	Head types
-	Standard model
.27	Integrated overpress. relief valve

3	Motors
E	Shaded pole motor (AC)
AA	Capacitor motor (AC)
DC	Direct current motor
DCB	Brushless direct current motor

4	Voltages / Frequencies
230V / 50Hz 115V / 60Hz 100V / 50-60Hz	for AC motors
6 / 12 / 24V	for DC motors
12 / 24V	for DCB motors

NF 100-E / AA

NF 100-DC / DCB



Performance

Basic model	Flow rate at atmos. pressure (l/min.)	Max. suction head (mWg)	Max. pressure head (mWg)
NF 100-E	1.2	4	10
NF 100-AA	1.2	4	10

Motor selection	E	AA
Voltage (V)	230V / 50Hz	230V / 50Hz
Power rating (W)	43	86
I max. load (A)	0.37	0.36
I max. (A)	0.43	0.50
EMC guideline	EN 55014	EN 55014
Motor protection factor	IP 00	IP 54
Weight	1100 g	2430 g

Performance

Basic model	Flow rate at atmos. pressure (l/min.)	Max. suction head (mWg)	Max. pressure head (mWg)
NF 100-DC	1.2	4	10
NF 100-DCB	1.2	4	10

Motor selection	DC	DCB
Voltage (V)	6 / 12 / 24	12 / 24
Power rating (W)	26 / 26 / 24	11 / 11
I max. load (A)	1.07 / 0.9 / 0.3	0.67 / 0.37
I max. (A)	4.4 / 2.2 / 1.0	0.93 / 0.46
EMC guideline	EN 55014	EN 55014-1 ¹⁾ EN 61000-2-6
Motor protection factor	IP 50	IP 30
Weight	600 g	480 g

¹⁾ In order to comply with the above standards attention must be paid to the specifications in the operating instructions.

NF 100-E

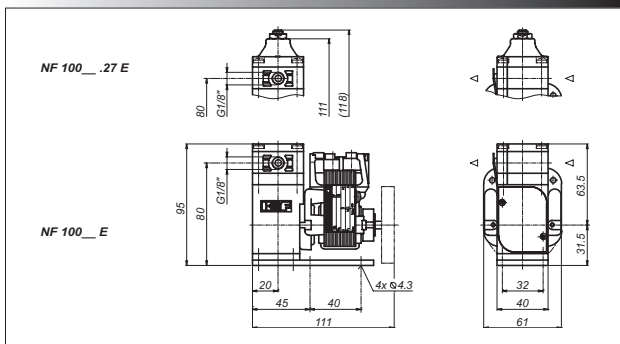

NF 100-DC

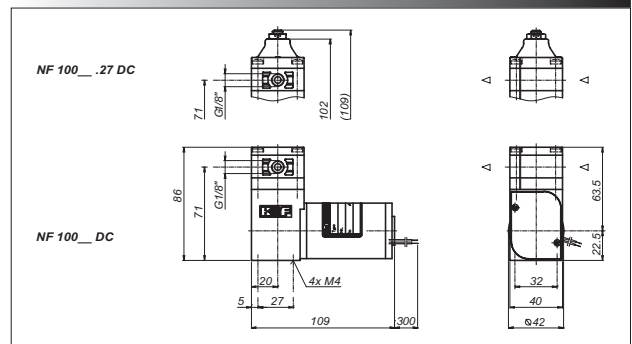

NF 100-AA

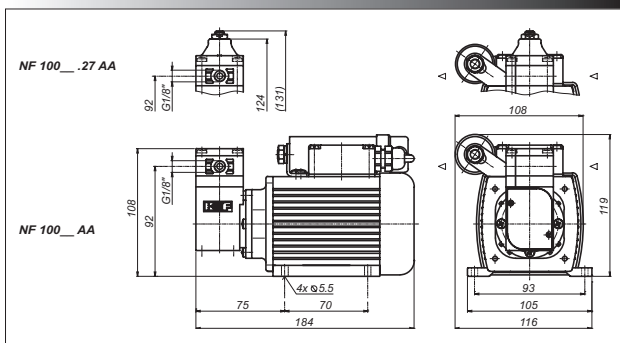

NF 100-DCB

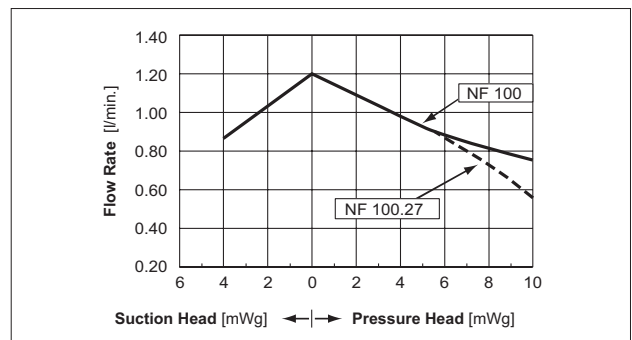
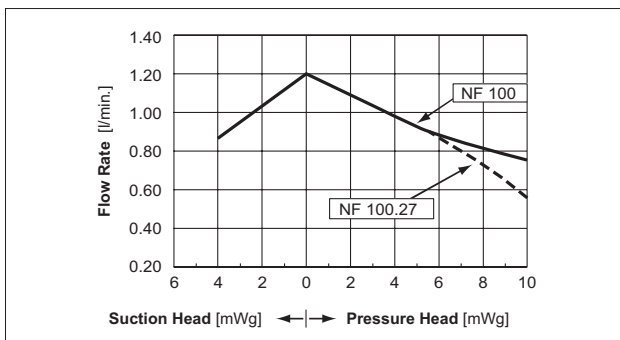
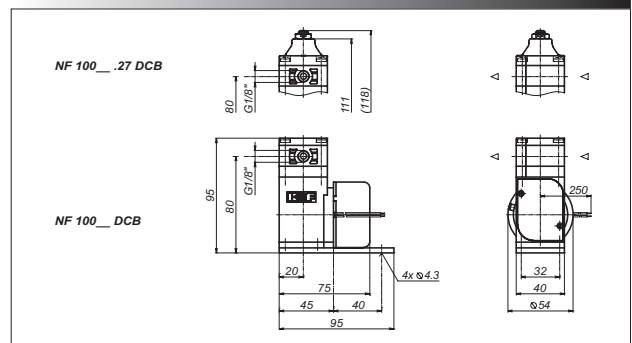

NF 1.100-E / AA

NF 1.100-DC / DCB



Performance

Basic model	Flow rate at atmos. pressure (l/min.)	Max. suction head (mWg)	Max. pressure head (mWg)
NF 1.100-E	1.3	4	60
NF 1.100-AA	1.3	4	60

Motor selection	E	AA
Voltage (V)	230V / 50Hz	230V / 50Hz
Power rating (W)	66	86
I max. load (A)	0.42	0.36
I max. (A)	0.50	0.50
EMC guideline	EN 55014	EN 55014
Motor protection factor	IP 00	IP 54
Weight	1600 g	2450 g

Performance

Basic model	Flow rate at atmos. pressure (l/min.)	Max. suction head (mWg)	Max. pressure head (mWg)
NF 1.100-DC	1.3	4	60
NF 1.100-DCB	1.3	4	60

Motor selection	DC	DCB
Voltage (V)	6 / 12 / 24	12 / 24
Power rating (W)	39 / 33 / 34	18 / 18
I max. load (A)	2.7 / 1.3 / 0.5	1.29 / 0.75
I max. (A)	6.5 / 2.8 / 1.0	1.50 / 0.75
EMC guideline	EN 55014	EN 55014-1 ¹⁾ EN 61000-2-6
Motor protection factor	IP 50	IP 30
Weight	720 g	500 g

¹⁾ In order to comply with the above standards attention must be paid to the specifications in the operating instructions.

NF 1.100-E

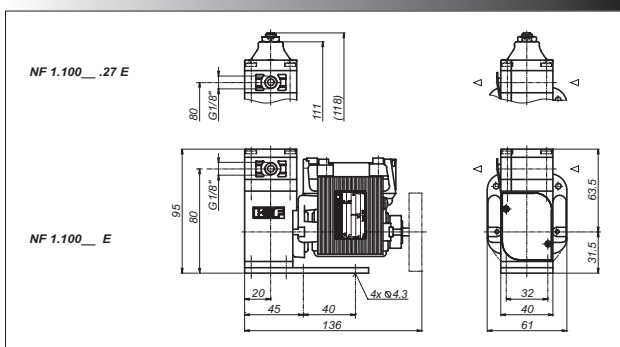

NF 1.100-DC

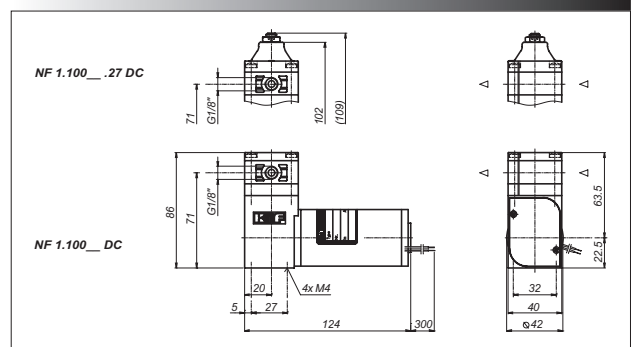

NF 1.100-AA

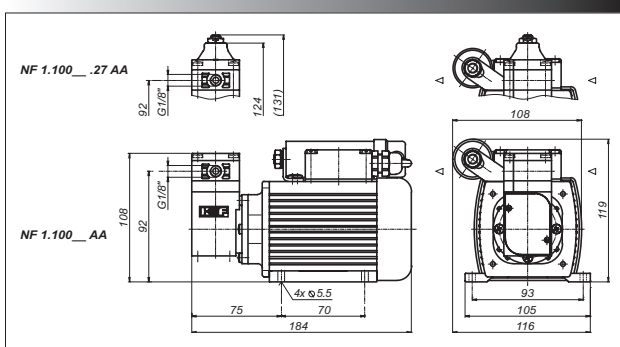

NF 1.100-DCB

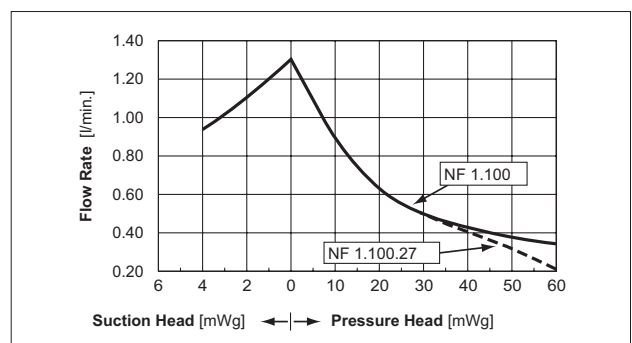
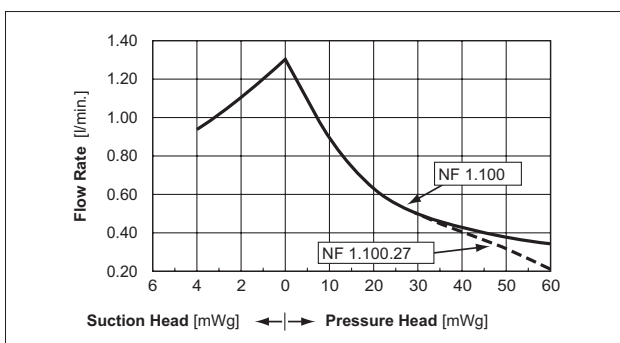
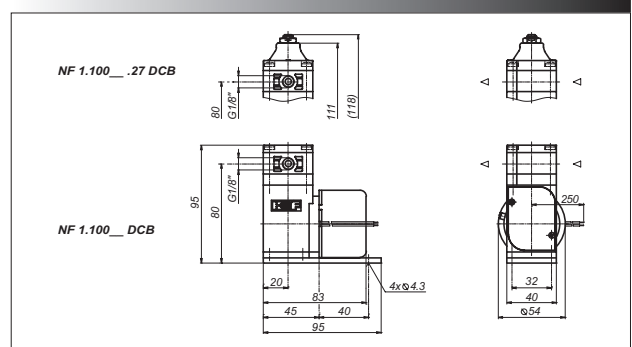



The NF 100/1.100 pump range comes with many other options. If you require any further information concerning the following features, our local sales representative would be very happy to be of assistance.



Tandem version (twin headed pump)

The tandem liquid diaphragm pump allows two pump heads to be driven by one motor and is available with AC or DC motors.



Explosion proof motors

For use in areas where there is the additional hazard of explosions we can offer different levels of explosion proof motors, for example: EExe II T1-T4 or EExd IIB T1-T4.



Compressed air motors

If you can't use electricity in your application or perhaps you would like to use an already available compressed air source, then we can offer the NF 100/1.100 with an air driven motor.

Accessories

- Pulsation damper
- Pressure control valve / check valves
- Hoses
- Hose connections
- Shock mounts
- Suppression device for DCB motor (ID-No. 068713)

Further options

- Connection threads NPT 1/8"
- Variable head materials
- Motors with special frequencies and voltages
- The incorporation of customers special requirements, for example special electrical connections (Molex, AMP etc.)

KNF FLODOS AG, Wassermatte 2, CH-6210 Sursee, Switzerland
Telephone ++41 41 925 00 25, Fax ++41 41 925 00 35
www.knf-flodos.ch, info@knf-flodos.ch

INNOVATIVE
TECHNOLOGY
WORLDWIDE

